



EtherLink/3 Features

- Allows ASI controllers to connect via Ethernet
- Built-in Web Server for configuration and firmware upgrade
- RS-232 or RS-485 serial communications
- Supports one TCP/IP and multiple UDP/IP connections
- Easy to configure via Ethernet or serial port
- Intelligently detects and relays alarm events to ASI Weblink
- Remote Point Trending in Weblink
- Built-in network time synchronization (SNTP) and time-keeper functionality

The ASI EtherLink/3 is a high performance Ethernet to RS-232 or RS-485 Serial router that enables Ethernet connectivity on any ASI controller or network. The EtherLink/3 simultaneously supports multiple UDP/IP (RFC 768) clients from any LAN/WAN or Internet connected device.

Featuring a built-in Web Server, the EtherLink/3 can be easily configured in an Internet Explorer or Firefox web browser window. It can also be configured via the serial port using HyperTerminal or similar software.

The EtherLink/3 has switch selectable RS-232 or RS-485 serial communication. It connects directly to the ASIC/2 controller RS-232 Port. It connects directly to an RS-485 Local or System communication bus using the optional EtherLink RS-485 Cable and RS-485 switch settings.

SNTP (Simple Network Time Protocol) is used in the EtherLink/3 to perform time synchronization and time keeper functions for ASIC/1, ASIC/2, or SINC/3 controllers.

The ASI OPC Server connects to the EtherLink/3 using TCP/IP. ASI Expert can also connect directly through the EtherLink/3 via UDP/IP to provide full access to all devices on the ASI communication network.

The EtherLink intelligently detects ASI System bus Notify alarm and events and relays them over Ethernet to ASI Weblink 3 software.

The EtherLink listens for Remote Points on the serial port and relays messages with designated remote point numbers to Weblink 3 for logging and trending.

The EtherLink/3 is small and very easy to configure. It comes with an external wall-mount power supply, null modem cable, and user manual.

Upgrades to the flash memory can be done through the built-in web server or with a built-in XMODEM server over RS-232.

The EtherLink/3 is a cost effective way to communicate using ASI controllers to a new or existing network. It is compatible with private LAN/WANs and the Internet.

The EtherLink/3 extends the reach and connectivity of ASI Controls systems. It is well suited to deliver supervisory control via an Internet browser for applications such as retail store networks or telecom mechanical equipment shelters, or any campus with many buildings connected over an Ethernet network.



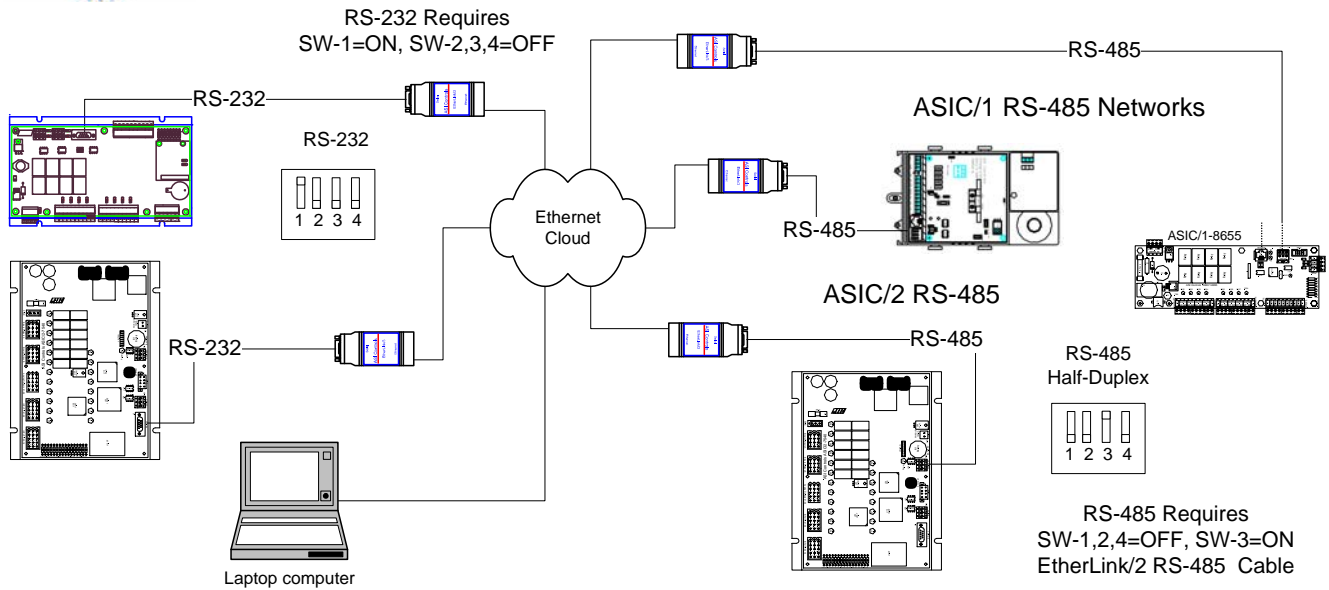

Specifications

Hardware

Processor: NS7530 32-bit
 NET+ARM, 55 MHz
 Memory RAM: 16 MB RAM
 Flash: 4 MB Flash
 LED Status: Power, Link, Activity
 Network Interface connector: RJ-45 10BASE-T

Ethernet Interface

IEEE 802.3/Ethernet compliant
 Auto-sensing 10/100 Mbit

Serial Interface

DB-9M connector (DTE)
 DB9-F to DB9-M RS-232 Cable and.
 DB9-F to DB9-F Null Modem included.

Switch selectable RS-232/RS-485 interface

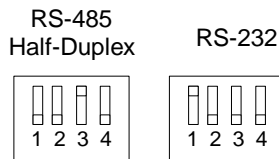

SINC/3: RS-232 Direct Connection (DCE)
 ASiC/2: RS-232 Connection (DCE)
 SINC/3: RS-232 Modem Connection (DTE)
 Requires DB-9F to DB-9F Null Modem
 ASiC/1: RS-485 Connection
 Requires EtherLink/3 RS-485 Cable

Physical Characteristics

Indication: 3 LEDs Link, Activity, Custom(red)
 Length: 3.9 inches (98 mm)
 Width: 1.7 inches (43 mm)
 Depth: 1.0 inches (25 mm)
 Weight: 0.14 lb (0.06 kg)

External Power Supply

Style: Wall-mount
 Input: 120 VAC, 60 Hz
 Output: 9 Vdc (370 mA) to 30 Vdc (110 mA) unregulated

Environmental

Temperature: 0 to 60 degrees C operating
 -40 to 90 degrees C non-operating
 Humidity: 10 to 95 percent non-condensing

Agency

Power Supply: UL listed, CSA approved
 EtherLink: FCC Class A , CE



Made in USA

How to Order:	Order Number
EtherLink/3	EtherLink/3

Accessories:	Order Number
Etherlink RS-485 Cable	EtherLink RS-485 Cable