



- BTL-ASC certified
- BACnet MS/TP RS-485 communication
- 2 Compressors, 3 Fan Speeds, Reversing Valve, Aux Heat
- Supports all common reversing valve configurations
- BACnet supervisor scheduling
- 1 extra analog and 2 extra digital inputs
- Proportional+Integral (PI) algorithm for smooth control
- Adjustable UNOCC setpoints
- °F or °C display
- Min/Max set-point, adjustable
- After-Hours mode, button push or BACnet initiation

The BACiQ-HP is a BTL-ASC listed BACnet-MS/TP thermostat designed for control of Heat Pump (HP) units with On/Off control of air conditioning.

BACiQ wall mount stats feature an integrated temperature sensor and built in LCD screen to display room temperature, setpoints and other status information. Display defaults to standard US units (°F) but metric units (°C) can optionally be selected.

Built-in sequences automatically control a reversing valve and up to 2 compressors with up to 3 fan speeds. The Proportional + Integral (PI) algorithm ensures smooth and consistent environmental conditioning.

BACiQ-HP wall mount stats can be configured in BACnet software by writing to BACnet object instances or at the device by pushing buttons.

Device configuration is preserved in the event of power loss. By default the controller resumes in occupied mode at power-up until a schedule is established, unoccupied mode is also supported.

The device supports after-hours overrides initiated from BACnet software or by push button directly on the unit. Default after-hours override duration of 30 minutes can be changed by writing to a BACnet object or by button push in engineering mode.

A convenient single-pole, double-throw relay provides flexibility for wiring a wide variety of reversing valves.



BACnet is a registered trademark of ASHRAE. ASHRAE does not endorse, approve or test products for compliance with ASHRAE standards. Compliance of listed products to the requirements of ASHRAE Standard 135 is the responsibility of BACnet International. BTL is a registered trademark of BTL.

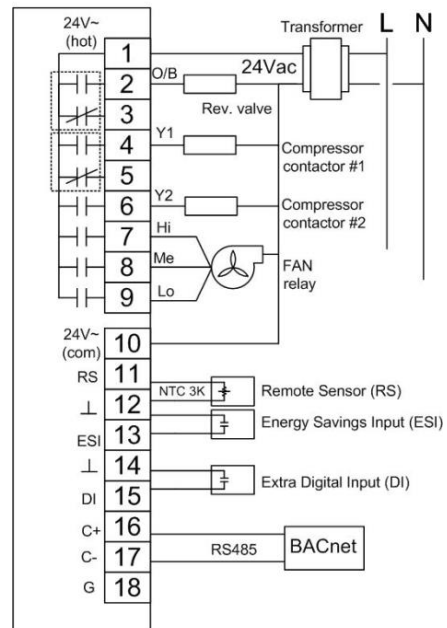



Specifications

Power

24Vac (+/-10%), 50/60 Hz

BACnet Communication

BTL certified Application Specific Controller (B-ASC)

Supports B-ASC & DS-RPM-B BIBBs

RS485, 2/ 3 wires connection

BACnet MS/ TP open protocol at 9.6, 19.2, 38.4, 57.6, or 76.8 kbps baud

N-8-1 data format (BACnet standard)

Display

Range: 14 °F to 140 °F / -10 to 60 °C

Resolution: 0.1 °F/°C

Accuracy: +/- 1.8 °F (at 77°F, output off)

Overall Dimensions

4.7" x 3.7" x 1.4" (HxWxD)

94mm x 118mm x 34mm

Weight: less than 1 lbs.

Color: white

Environment

32 °F to 122 °F (0 to 50 °C)

5%-95% RH (non-condensing)

Set-point Range

32~122 °F (default: 50~86 °F, adjustable)

0~50 °C (default 10~30 °C, adjustable)

Resolution: 0.5 °F (or 0.5 °C)

Setpoint Adjust

Pushbutton or BACnet communication

Relay Output for On/Off valve/actuator

2 SPDT + SPST relays for 1 or 2 stages of Cooling or Heating with Auxiliary Heat

Relay Output for Fan Control

Up to 3 SPST relays for 3-speed control

Electrical Rating

(2) SPDT relays: 1.2A/24Vac, inductive load

(4) SPST relays: 2A/24Vac, inductive load

Wiring

Screw Terminals, 14-22 AWG wire (1.5 mm²)

Mounting

Directly on to wall, panel, or 2×4 inch junction box

Metric: fits 65×65 mm junction box; hole pitch 60 mm

Control Sequence

Proportional plus integral (PI) applied to differential on/off control

Remote Sensor (RS) Input Interface

For connecting to external NTC Thermistor 3K ohm

Energy Savings Input (ESI) Interface

Optional energy conservation feature can be configured to enter Unoccupied mode if ESI is triggered by a normally open (N.O.) or normally closed (N.C.) dry contact relay

Extra Digital Input (DI) Interface

Optional energy conservation feature can be configured to stop cooling or heating and fan control outputs if DI is triggered by a normally open (N.O.) or normally closed (N.C.) dry contact relay

How to Order:	Part Number:
BTL-ASC heat pump controller, wall mount, integrated LCD screen, temperature sensor	BACiQ-HP

Example network diagram

