

2-Pipe Fan Coil

General Description

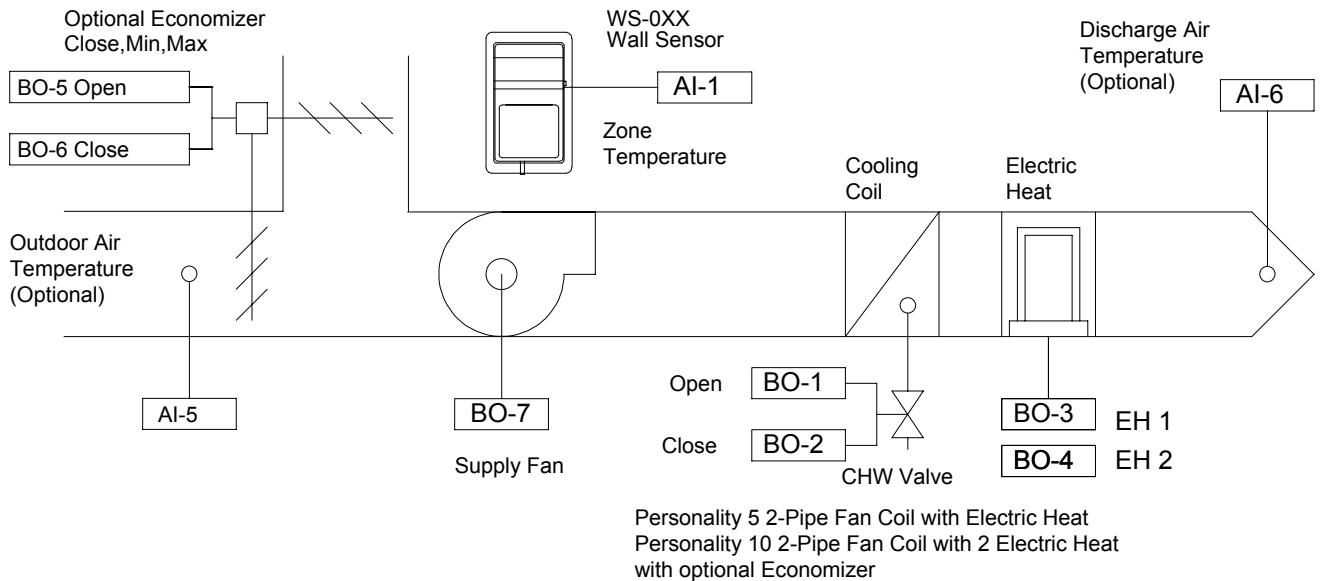

The ASIC/1-8255 is preprogrammed with different personalities for fan-coil applications. This application bulletin describes the sequence of operation used by the ASIC/1-8255 to control zone temperature with a 2-pipe fan-coil unit. The ASIC/1-8255 uses a modulating water valve with tri-state actuator to regulate cooling or heating. Heating is provided, by changeover of chilled water to hot water (Personality 1), or 1 stages of electric heating (Personality 5), or 2 stages of electric heating (Personality 10). An optional economizer may be used in all personalities.

2-Pipe Fan Coil Personalities

	Cooling Only	1 Stage Electric	2 Stage Electric
2-Pipe Fan Coil	1	5	10

Inputs

The ASIC/1-8255 controller has specific inputs for zone temperature, optional water temperature, optional discharge air temperature, optional outdoor air temperature, and optional occupancy sensor. The default input types are set at the factory. Inputs that are not required for the sequence may be used for monitoring, and may be scaled to read various analog sensors.

Wall Sensor Connections

Zone temperature sensor is on input 1. Typically, the zone temperature on the WS-0XX, or WT-0XX wall sensor, is connected to the controller using a SCP-XXX sensor cable. Alternately, a zone or return air temperature sensor may be attached on the input blade, IN1, and input common, COM. If there is no zone temperature sensor, then the zone sensor input is in fault, all outputs are off, and it does not try to control.

The afterhours push-button on the WT-0XX, or WS-0XX wall sensor if used, is always on input 2. If Afterhours Enable is Yes, then shorting the input to zero will initiate afterhours override mode for an Afterhours Time Allowed.

Input 2 may also be used for the user adjust switch on the WT-0XX Wall Sensor. When User Adjust Enable is set and input 2 is configured for user adjust switch, the zone temperature setpoint may be adjusted up or down by the User Adjust Setpoint, based on the condition of Input 2.

Input 3 is used for Interlock and may also be used for variable user adjust with the WS-0XX wall sensor. When User Adjust Enable is set and input 3 is configured for Variable User adjust, 10 to 30 kohm, the zone temperature setpoint may be adjusted up or down by the User Adjust Setpoint, based on the condition of input 3.

Water Loop Temperature

An optional Water Loop Temperature sensor, TS-I (insertion) or TS-S (strap-on), on input 7 may be used for auto-changeover if Changeover Setpoint is not zero. If the sensor on input 7 is in fault, then changeover is ignored. Changeover operation is described below. The temperature sensor uses the factory provided 1.82 kohm pull-up resistor, R21.

Discharge Air Temperature

An optional Discharge Air Temperature sensor, TS-D (duct), may be placed on input 6, for temperature monitoring or optional discharge air temperature control. The temperature sensor uses the factory provided 1.82 kohm pull-up resistor, R20.

Outdoor Air Temperature

An optional Outdoor Air Temperature sensor, TS-O, may be placed on input 5. The outdoor sensor can provide for temperature monitoring, economizer control, and heating or cooling lockout control. The temperature sensor requires the *addition* of a 1.82 kohm pull-up resistor, R19.

Note: If the outdoor air temperature is to be broadcast to the unit by an ASIC/2-7040, then the pull-up resistor and an external 3.32 kohm resistor is required to give a nominal value (74 °F) and to prevent the input from going into fault.

Occupancy Sensor/ Auxiliary Sensor

An optional occupancy sensor, MOT Series, or switch may be used on input 8 to change the control state from occupied to unoccupied.

An optional Auxiliary Temperature sensor, TS Series, may be placed on input 8 for temperature monitoring. The temperature sensors uses the factory provided 1.82 kohm pull-up resistor, R22. When the occupancy sensor is used in combination with a temperature sensor, then the temperature sensor is not read when the contacts are closed when signaling unoccupied. The use of the occupancy sensor is discussed in APB-226, ASIC/1 Occupancy Sensor.

Control Mode

The controller determines the Control Mode, Heating, Deadband, or Cooling by comparing the zone temperature to the Active Heating Temperature Setpoint and Active Cooling Temperature Setpoint.

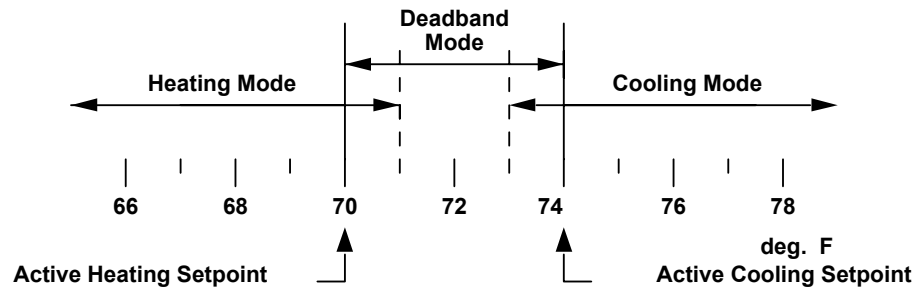

The controller enters the Cooling Control Mode when the zone temperature equals or is greater than the Active Cooling Temperature Setpoint. The control reenters the Deadband mode, when the zone temperature is 1 °F below the Active Cooling Temperature Setpoint and the calculated Cooling Requirement is equal to zero.

The control enters the heating mode when the zone temperature is equal to or less than the Active Heating Temperature Setpoint. The control reenters the Deadband mode when the zone temperature is 1 °F greater than the Active Heating Temperature Setpoint and the calculated Heating Requirement is equal to zero.

Active Temperature Setpoints

The controller maintains the zone temperature between Active Cooling and Heating Temperature Setpoints. The Active Cooling and Heating Temperature Setpoints are based on Control State, the Active User Adjust based on the position of the Slide Switch or Variable User Adjust, and the Active Demand Limit Reset.

If User Adjust Enable is yes, the Active Temperature Setpoints may be modified either by the User Adjust Switch on a WT-0XX wall sensor, or by the variable user adjust potentiometer on a WS-0XX wall sensor depending on the input configuration. The

October 1998

Active Cooling and Heating Temperature Setpoints are adjusted up or down a fraction of the User Adjust Setpoint depending on the user adjust switch or potentiometer setting..

If the Active Demand Level is non-zero, the Active Temperature Setpoints are also modified by a fraction of the Demand Reset Range [Default 6] as the Active Demand Level goes from 0 to 6. The Active Cooling Temperature Setpoint is reset upwards and the Active Heating Temperature Setpoint is reset downwards. If Shed Fan Enable is yes, the Fan is turned off when the Active Demand Level reaches the Demand Shed or Rotate Level.

Cooling and Heating Requirement

In Deadband Control Mode, the Heating and Cooling Requirements are zero.

In the Cooling or Heating Control Mode, the Cooling or Heating Requirement is calculated using a PI control loop.

The change in heating or cooling requirement is calculated every 30 seconds.

In heating: Error = Active HTG SP - Zone Temp

Δ Error = Previous Zone Temp - Zone Temp

or in cooling: Error = Zone Temp - Active CLG SP

Δ Error = Zone Temp - Previous Zone Temp.

Δ Requirement = (100%/ThrottleRange)*[Error*(CalcTime/Int Time) + Δ Error]

The factory setting for throttle range is 4.0 degrees, and for integral time is 2.5 minutes.

Cooling Mode

When in Cooling Control mode and Not in Changeover, the controller drives the tri-state water valve from closed to open based on the Cooling Requirement.

When in Cooling Control mode and in Changeover, the tri-state water valve is maintained at closed position when in changeover.

Deadband Mode

When in Deadband Control mode, the controller maintains the tri-state water valve at the closed position.

Heating Mode

When in the Heating Control Mode and NOT in changeover, the controller maintains the tri-state water valve at closed position.

When in the Heating Control Mode in changeover, the controller drives the tri-state water valve from closed to open based on the Heating Requirement.

The operation of the tri-state water valve output is discussed in more detail below.

Control State

The Control State determines which Cooling and Heating Temperature Setpoints are used for zone temperature control. Four control states are possible: Occupied, Unoccupied, Night Setback, and Morning Ready. If the Clock is not synchronized, the Control State is Occupied by default. Otherwise the Control State is determined by the Daily Event Schedule.

The Control State may be overridden via a message broadcast over the communication bus from software or an ASIC/2-7040 controller. The controller state may be returned to OCC from NSB or Unoccupied, when the Afterhours Enable is yes and the push-button on the Wall Sensor is pushed. The controller state may be also overridden to Unoccupied from Occupied by an MOT Series Occupancy Sensor on input 8.

Morning Ready (MRDY) State

Morning Ready is meant as a prelude to Occupied state, to ready the building for daily use. For Morning Ready, the control sequence operates at full-capacity heating or cooling until the zone temperature is moved into the Deadband region. The Occupied Temperature Setpoints are used in Morning Ready.

Control Features

Emergency Modes

Two emergency modes, Emergency 1, and Emergency 2, are overrides which are received over the communication line and remain in effect until cleared over the communication line. Emergency modes are maintained through loss of power.

While in Emergency 1 state the controller immediately turns ON the fan, drives the water valve to closed, turns ON the lighting output, and turns OFF any other outputs (including electric heat). No other state may be entered until Emergency 1 has been cleared via the communications line.

If in Emergency 2, no other state except Emergency 1 may be entered until Emergency 2 has been cleared via the communications line. While in Emergency 2 state the controller immediately turns OFF the fan, drives the water valve to closed, turns ON the lighting output, and turns OFF any other outputs (including electric heat).

Changeover

A changeover feature is available for two-pipe personalities which modifies the modes of operation in Heating, Deadband, and Cooling control modes. In changeover it is assumed that the water loop temperature is appropriate for heating. Changeover is useful for applications where a single pipe serves both heating and cooling at different times.

In the changeover Heating Mode, the water valve modulates based on the zone Heating Requirement. In a cooling only 2-pipe fan coil (personality 1), if there is a call for heating and it is not in changeover, then the changeover alarm is set and the tri-state water valve is closed.

If the controller is in changeover and there is a call for cooling, then the changeover alarm is set and the tri-state water valve is closed.

If Local Heat Enable is set, then the electric heat (if available) is used in addition to changeover hot water heat, whenever the controller is operating in changeover heating mode.

There are two types of changeover: Auto-changeover and remote changeover.

Auto-changeover requires installation of a water loop temperature sensor, TS-I or TS-S, on input #7. If the measured water loop temperature is greater than the Changeover Setpoint, the controller goes into a heating only changeover mode. If the Changeover Setpoint is 0 F (default), the auto-changeover feature is disabled.

Remote Changeover

A command may be sent by an ASIC/2-7040 or by user software via the communications line to force the changeover mode. A remote command to set changeover ON forces the system to control in the changeover heating mode. A remote command to set changeover OFF prevents all changeover control action. Remote commands always take priority over auto-changeover. A remote command to restore changeover clears changeover ON and changeover OFF and enables the auto-changeover control action.

DAT Control

If the discharge air temperature sensor, TS-D, has been installed on input 6, and the user has set DAT Control Enable to yes, then control resets the discharge air temperature setpoint based on the active cooling or heating requirement. The heating and cooling requirement is calculated as a function of the zone temperature, using the PI algorithm. The DAT Setpoint is then calculated based on the heating or cooling requirement. The changeover status is examined to determine whether heating or cooling operations are possible.

Cooling Mode

The Active DAT Setpoint is proportional to the cooling requirement between DAT Minimum CLG Setpoint and DAT Maximum CLG Setpoint.

$$\text{Active DAT Setpoint} = T_{\text{cool max}} + (T_{\text{cool min}} - T_{\text{cool max}}) * (\text{Cooling Requirement})$$

- o DAT Calculation in 1/6 s increments is as follows:
CLG Open Drive time = (1s/6)*(DAT - DAT SP)*CLG_Open_Param/5
CLG Close Drive time = (1s/6)*(DAT SP - DAT)*CLG_Close_Param/5

Heating Mode

The Active DAT Setpoint is proportional to the heating requirement between DAT Minimum HTG Setpoint and DAT Maximum HTG Setpoint.

$$\text{Active DAT Setpoint} = T_{\text{heat max}} + (T_{\text{heat min}} - T_{\text{heat max}}) * (\text{Heating Requirement})$$

- o DAT Calculation in 1/6 s increments is as follows:
HTG Open Drive time = (1s/6)*(DAT SP - DAT)*HTG_Open_Param/5
HTG Close Drive time = (1s/6)*(DAT - DAT SP)*HTG_Close_Param/5

Heating and Cooling Lockouts

It is possible to lockout Heating or Cooling either completely or when the outdoor temperature reaches some Outdoor Air Temperature Lockout Setpoint. The heating and cooling calculations and modes function normally even if lockouts are enabled.

If the Lockout Heating is enabled then all heating outputs, electric heat, hot water valve, and changeover heating outputs are locked out when the controller is in the heating mode.

If the OAT Heating Lockout is enabled and the Outdoor Air Temperature on Input 5 is greater than the OAT HTG Lockout Setpoint then all heating outputs, electric heat, hot water valve, or changeover heating outputs are locked out when the controller is in the heating mode.

If the Lockout Cooling is enabled, then the chilled water valve outputs are locked out when the controller is in the cooling mode.

If the OAT Cooling Lockout is enabled and the Outdoor Air Temperature on Input 5 is less than the OAT CLG Lockout Setpoint, then the cooling output, chilled water valve, is locked out when the controller is in the cooling mode.

Economizer

On/Off Economizer

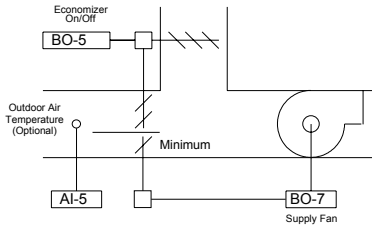

When Economizer Enable is yes and Economizer 3-Position Enable is no, an outdoor damper on output 5 can be energized when the conditions are suitable for free cooling.

In the Heating mode or Deadband entered from Heating when the fan is On, Economizer Output is off. In Cooling mode, or in Deadband entered from Cooling, when the fan is On and Economizer Low Limit Temp SP < OAT and OAT < Economizer Temperature SP, then economizer output is On.

When the fan is On and OAT < Economizer Low Limit Temp SP or OAT > Economizer Temperature SP, then Economizer output is off. If the Outdoor Air Temperature Sensor is in fault, then the economizer output is Off.

3-position Economizer

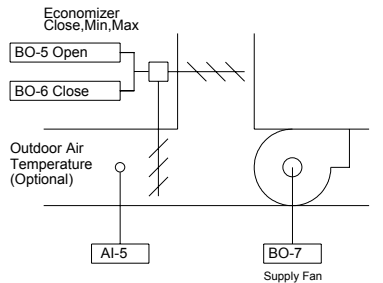

When Economizer Enable is yes and Economizer 3-Position Enable is yes, a tri-state outdoor damper can be controlled from closed, to minimum, to maximum depending on the conditions for free cooling. Economizer Open is on Output 5. Economizer Close is on Output 6. The 3-position Economizer position is based on a percentage of the drive time. The Economizer will drive Open or Closed so that the Active Economizer Position SP is equal to the Active Economizer Position.

When the fan is off, the economizer drives to the Economizer Closed Position.

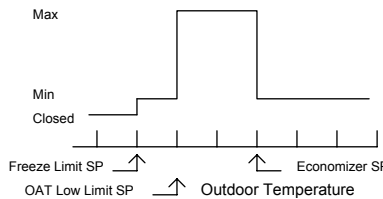

When the fan is On and Economizer Low Limit Temp SP < OAT and OAT < Economizer SP, then Economizer output is at Economizer Maximum Position.

When the fan is On and Economizer OAT < Economizer Low Limit Temp SP or OAT > Economizer SP, then Economizer output is at Economizer Minimum Position.

When the fan is On and Economizer OAT < Economizer Freeze Limit SP, then the economizer output is closed. If the Outdoor Air Temperature Sensor is in fault, then the economizer output is closed

With FW255A1.7 the economizer is first stage of cooling when available and locks out other cooling when the cooling calculation is < 25%. The Economizer damper is modulated from minimum to maximum when the cooling calculation goes from 0 to 25%. A new parameter EconoCooling Requirement has been added to identify the economizer requirement.

The Economizer at minimum if OAT < Economizer Low Limit Temp SP or if OAT > Economizer SP.

Outputs

Fan Output

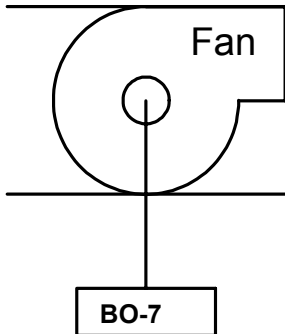

The ASIC/1-8255 has On/Off fan control. The fan is On whenever there is a call for heating or cooling. In Deadband the fan follows the appropriate state of Intermittent Fan Enable.

If Intermittent Fan Enable is Yes in Occupied, or if NSB Intermittent Fan Enable, UNOC Intermittent Fan Enable, or MRDY Intermittent Fan Enable is Yes, then the Fan turns off in Deadband after a Fan Wait Time in the respective control states.

If Intermittent Fan Enable is No in Occupied or if NSB Intermittent Fan Enable, UNOC Intermittent Fan Enable, or MRDY Intermittent Fan Enable is No, then Fan is always on in Deadband in the respective control states.

Tri-state Water Valve Output

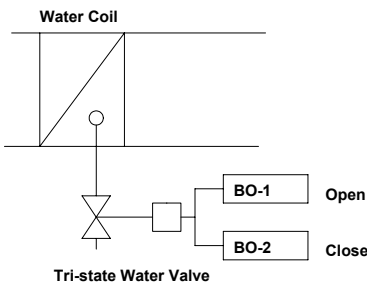

In a controller with modulated tri-state water valve (Personality 1, 5, or 10, the valve is opened or closed a fraction of the CHW Valve Base Time in proportion to the Cooling Requirement, unless DAT Control Enable has been set. The valve is opened or closed a fraction of the CHW Valve Base Time in proportion to the Cooling Requirement based on a 5-value Cooling Valve Output Table.

The output to be controlled is identified by the CHW Valve Open Mask and CHW Valve Closed Masks. The functional status of the CHW Valve output is shown by the CHW Valve Output Status.

If DAT Control Enable has been set, then the valve is driven open or closed based on the deviation from the Active DAT Setpoint.

Electric Heat Output

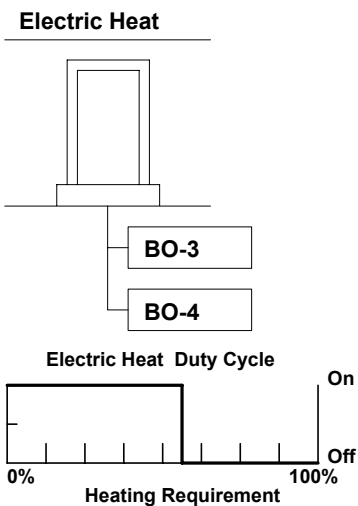

One Stage (Personality 5) or Two Stages (Personality 10) of Electric Heating output is used to maintain the calculated heating requirement. The output to be controlled is identified by the Electric Heat 1 Mask, Output 3, and Electric Heat 2 Mask, Output 4. The functional status of the Electric Heat Outputs is shown by the Electric Heat 1 & 2 Output Status.

For a controller with 2 stages of electric heat (Personality 10), Stage 1 duty cycles in proportion to the Electric Heat Base Time from 0 to 100%, as the Heating Requirement goes from 0 to 50%. Stage 2 duty cycles in proportion to the Electric Heat Base Time from 0 to 100%, as the Heating Requirement goes from 50 to 100%.

For a controller with 1 stage of electric heat (Personality 5), Stage 1 duty cycles in proportion to the Electric Heat Base Time from 0 to 100%, as the Heating Requirement goes from 0 to 100%.

1 Stage Electric Heat at ~56% HTG

Other Outputs

Auxiliary Cooling Output (Optional)

An optional auxiliary cooling output is provided. If Auxiliary Cooling Enable is yes in the Cooling Mode, and the Cooling Requirement is 100 % and the zone temperature exceeds the active cooling setpoint by an Auxiliary Cooling Offset [Default 2 oF] for a Auxiliary Cooling Delay Time [Default: 120 s], then an auxiliary cooling output is energized. The output to be used is assignable using the Auxiliary Cooling Output Mask [Default: None]. Once energized, the auxiliary cooling output remains on until zone temperature falls below the Active Cooling Setpoint and the cooling requirement falls below 100% by an amount given by the Auxiliary Cooling Hysteresis. [Default: 5]

Auxiliary Heating Output (Optional)

If Auxiliary Heating Enable is set, the auxiliary heating output goes on whenever the controller is in the heating mode. The output to be used is assignable using the Auxiliary Heating Output Mask [Default: None]. Once energized, the auxiliary heating output turns off when the control enters the Deadband control mode. This output is completely independent of the hot water valve or electric heat operation. It may be used to control baseboard heat used in conjunction with terminal boxes.

Auxiliary 1, 2, 3 Output (Optional)

The ASIC/1-8255 allows up to 3 outputs for auxiliary outputs which do not follow any schedule. They can be overridden On or Off, and remain in the last state commanded. The output to be controlled is identified by the Aux 1, 2, 3 Masks which are initially not assigned. The functional status of the Aux 1, 2, 3 Outputs is shown by the Auxiliary 1, 2,3 Output Status.

Lighting Output (Optional)

Each ASIC/1 has the ability to control lighting. The Lighting schedule will automatically turn the lights on and off. By equipping the ASIC/1 with a WS-0XX wall sensor with push button override, the lights can be operated manually by the occupant during Occupied and Morning Ready States by pressing the button on the side of the zone sensor without affecting HVAC operation.

During Unoccupied and Night Setback States, depressing the push button will return the control to Occupied, and the lights will come on and stay on for Afterhours Time Allowed. During Emergency 1 and Emergency 2, the push-button has no effect.

If an occupancy sensor is used and if Lights Occupied Enable is yes, then the lights are on whenever the Lighting Schedule is On, or the Control State is occupied.

Blink Warning: One minute before automatic shut off of lights as designated in the daily event schedule, or at the end of the afterhours override period, the lights will blink off and back on again. Pressing the afterhours button will re-start the lights.

Alarms

Alarm 1 - Zone Temperature Alarm

If the zone temperature is above the Active Cooling Temperature Setpoint by the Zone Temperature Alarm Range, a High Zone Temperature Alarm is set. If the Zone temperature is below the Active Heating Temperature Setpoint by the Zone Temperature

October 1998

Alarm Range, a low Zone Temperature Alarm is set. No other actions are taken in response to a zone temperature alarm.

Alarm 2 - Discharge Air Temp Alarm

If the Discharge Air Temperature on input 6 is above the Active Discharge Air Temperature Setpoint by the Discharge Air Alarm Range, a High Discharge Air Temperature Alarm is set. If the Discharge Air Temperature is below the Active Discharge Air Temperature Setpoint by the Discharge Air Alarm Range, a low Discharge Air Temperature Alarm is set. No other actions are taken in response to a Discharge Air Alarm.

Alarm 3 (LO) - Changeover Alarm

If the controller is in changeover and there is a call for cooling, then a changeover alarm is set and the changeover valve is closed.

For 2-pipe fan coil with no electric heat (Personality 1), if the controller is in not changeover and there is a call for heating, then a changeover alarm is set and the changeover valve is closed.

Communications

The ASIC/1-8255 communicates at 1200 baud, 9600 baud, or 19,200 baud on the remote bus using RS-485 twisted pair communication wire, connected to remote screw terminal connector, TB-4. Access to the ASI communication bus is through a SINC/2-2000 system interface which can also be used to broadcast time to synchronize the network of ASIC/1 controllers.

Communication with the remote bus can also be established through the WS-0XX wall sensor using a SINC/1-1030 Portable Interface connected to a lap-top computer running ASI SET8255 Setup Software. It can also communicate through the WT-0XX in the remote communication mode. *The local communication mode is not supported.*

Each controller has a unique 16 bit address, and may also have a separate 8 bit group address. It will also respond to the global addresses 23125 (5A55h) and 23130 (5A5Ah).

System Component Checklist

Inputs

Description	Part Number	Quantity
Optional Outdoor Air Temperature Sensor (IN-05)	TS-O	0,1
Optional Discharge Air Temperature Sensor (IN-06)	TS-D-8	0,1
Optional Water Loop Temperature Sensor (IN-07)	TS-I-4, or TS-S	0,1
Optional Auxiliary Temperature Sensor (IN-08)	TS-D-8	0,1
Optional Occupancy Switch (BI-08)	MOT Series	0,1
Wall Mounted Zone Temperature Sensor	WS-0XX	1
Sensor Cable	SCP-0XX	1
Communication Cable twisted pair.	22-24 ga twisted	
ASIC/1-8x55 Enclosure Cover Kit	CE-055	0,1

NOTE: Consult ASIC/1-8X55 Installation manual for configuration of inputs.

Outputs

Description	Part Number	Quantity
Fan Coil Controller	ASIC/1-8255	1
24 Vac Transformer		1
24 Vac Fan Control Relay with line voltage contacts		1
Water Valve with 24 Vac Tri-state Operator		1
Economizer Damper with 24 Vac Tri-state Operator		0,1
24 Vac Electric Heat Relay with line voltage contacts		0,1,2,
24 Vac Auxiliary CLG Output Relay (Optional)		0,1
24 Vac Auxiliary HTG Output Relay(Optional)		0,1
24 Vac Auxiliary Output Relay (Optional)		0,1,2,3
24 Vac Lighting Relay (Optional)		0,1

NOTE: The ASIC/1-8255 must be connected to a solid building ground. Metallic-oxide Varistors, MOV, may also be used across relay contacts to provide further protection from transients. If current interrupting relays are in series with the output circuits they must be protected with MOVs across the Relay Contacts

Wiring Layout

2-pipe Fan Coil with up to 2 Stages of Electric Heat

Typical 2-pipe Fan Coil with up to 2 Stages of Electric Heat, for use with the following personalities: Personality 1, Modulate Cooling and Changeover Heating, Personality 5, Modulate Cooling and 1 stage of electric heat; and Personality 10, Modulate Cooling and 2 stages of electric heat. Note: Triac outputs sink 24 Vac to common.

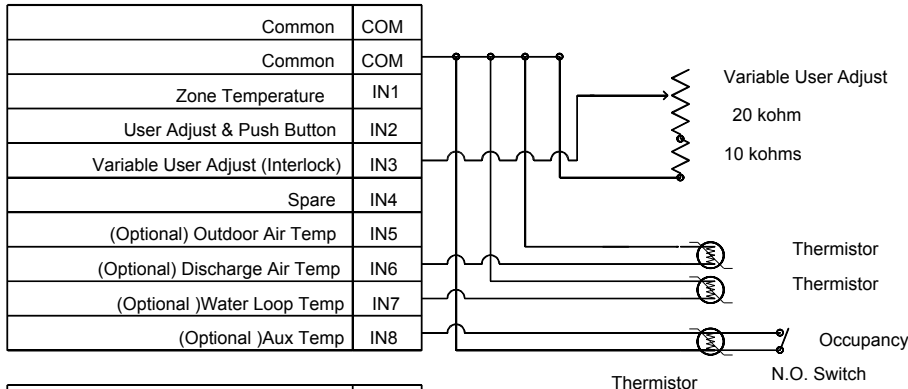
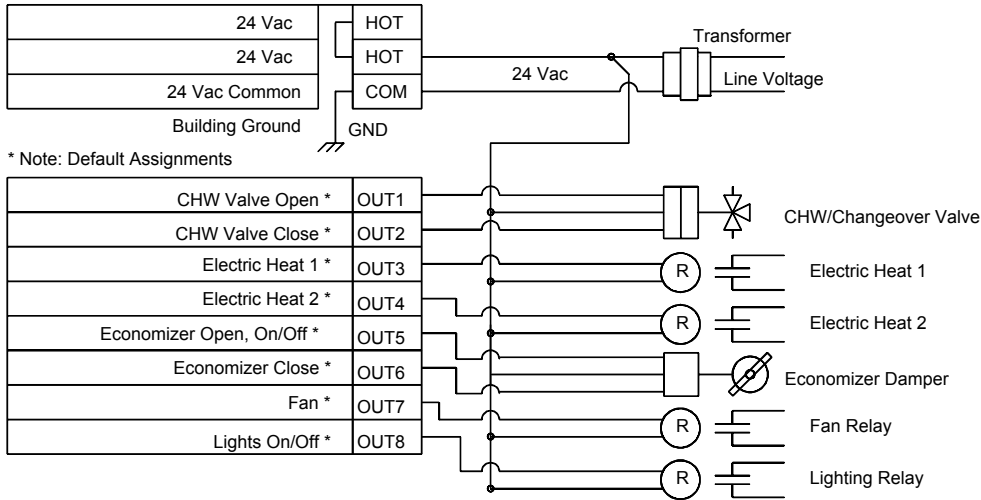

Remote Communications HI(+)	TB4-1
Remote Communications LOW(-)	TB4-2
Shield / Common (c)	TB4-3

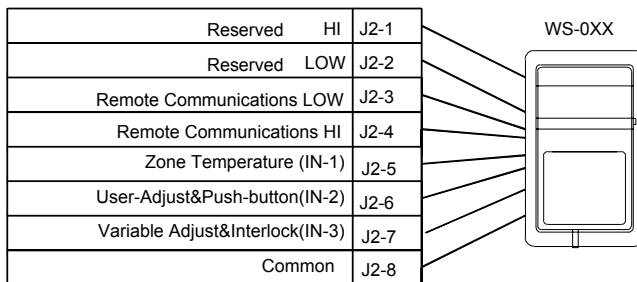

w_fc_2pe.skd
09/10/97

ASIC/1-8255 Fan Coil Controller
with 2 Pipe Cooling & Changeover Heating
with Electric Heat