

Intermittent Fan VAV

Application

ASIC/1-6000 Personality 12
Intermittent Fan VAV with HW Heat

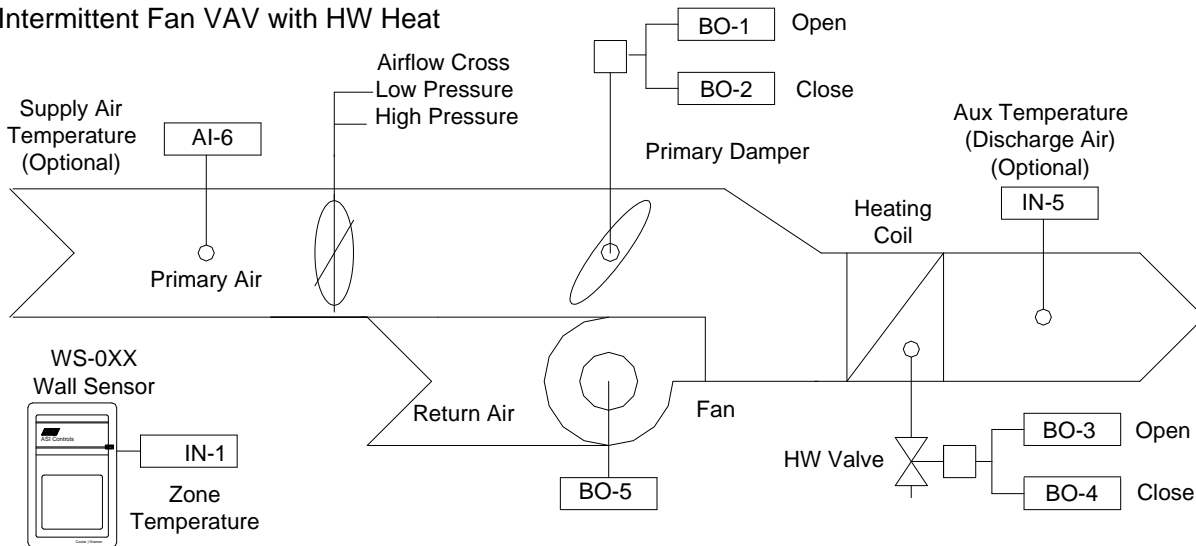

s6000_ifanhw.dwg 2004-10-05

This application bulletin describes the sequence of operation used by the ASIC/1-6000 to control zone temperature with a fan-powered parallel VAV system with intermittent fan. The ASIC/1-6000 uses a primary airflow sensor to give pressure independent control of the variable air volume cooling. Heating is provided with optional proportional or thermic valve hot water heat, or up to 3 stages of electric heating. The ASIC/1-6000 is preprogrammed with different personalities for fan-powered parallel VAV terminals.

Intermittent Fan Personalities

	No Reheat	1 Stage Electric	2 Stage Electric	3 Stage Electric	HW Valve Open/Close	Thermic Valve
Intermittent Fan	16	6	7	NA	12	19

Inputs

The ASIC/1-6000 controller has specific inputs for zone temperature, primary airflow, and optional secondary airflow, and optional supply air temperature, and optional occupancy sensor. The default input types are set at the factory. Inputs that are not required for the sequence may be used for monitoring.

Primary Airflow

The ASIC/1-6000 uses an primary airflow sensor to give pressure independent control of the variable air volume. The primary airflow sensor is installed on input 4 is calibrated at zero airflow. An airflow filter, AF-001, is required on the inlet side of the airflow transducer, is installed in the enclosure.

The controller measures the air velocity in feet per minute (ft./min) assuming a standard velocity K-factor of 2338 ft/min. The velocity K-factor is the air velocity in ft/min required to generate a velocity pressure of 1 inch water column (1 "wc =249 Pa) The velocity K-factor is provided by the VAV box manufacturer for a particular box size and flow cross. The airflow volume Q in CFM is calculated based on the actual K-factor in feet per minute , and duct area in square feet.

$$Q \text{ (CFM)} = \text{Area (ft}^2\text{)} * \text{Velocity(ft/min)} * (\text{K-factor}/2338)$$

Field adjustment of the velocity K-factor may be done by the air balancer using the air balance screen on the setup software.

Wall Sensor Connections

Zone temperature sensor is normally on input 1. Typically, the zone temperature on the WS-0xx wall sensor, is connected to the controller using a SCP-XXX sensor cable. Alternately, a zone or return air temperature sensor may be attached on input blade, IN1. If there is no zone temperature sensor , then the zone sensor input is in fault, all outputs are off, and it does not try to control.

The afterhours push-button on the WS-0X1 wall sensor if used, is always on input 2. If Afterhours Enable is Yes, then shorting the input to zero will initiate afterhours override mode for an Afterhours Time Allowed.

Input 3 is used for Interlock and may be used for variable user adjust with the WS-0XX wall sensor. When User Adjust Enable is set and input 3 is configured for Variable User adjust, 10k to 30 kohm, the zone temperature setpoint may be adjusted up or down by the User Adjust Setpoint, based on the condition of input 3.

Support is also provided for the WS-051 Digital Display Wall Sensor. The WS-051 has a zone temperature sensor on input 1 and provides both Occupied Temperature Setpoint change and afterhours override. A jumper, JMP1, may be set to provide power to the WS-051 via input 2.

Auxiliary Temperature Sensors

An optional a duct temperature sensor, TS-DO, may be placed on input 5 or 6 for temperature monitoring. The auxiliary temperature sensors use the factory provided 3.32 kohm pull-up resistor.

The duct sensor on input 6 is used for auto-changeover if Changeover Setpoint is not zero. If the input on input 6 is in fault, then changeover is ignored. Changeover operation is described below.

Control Mode

The controller determines the Control Mode, Heating, Deadband, or Cooling by comparing the zone temperature to the Active Heating Temperature Setpoint and Active Cooling Temperature Setpoint.

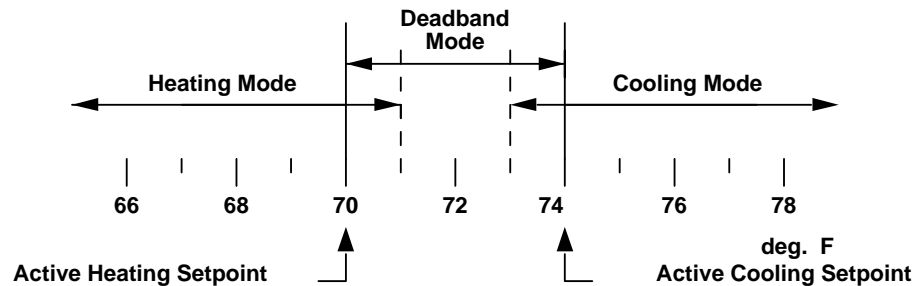

The controller enters the Cooling Control Mode when the zone temperature equals or is greater than the Active Cooling Temperature Setpoint. The control reenters the Deadband mode, when the zone temperature is 1 °F below the Active Cooling Temperature Setpoint and the calculated Cooling Requirement is equal to zero.

The control enters the heating mode when the zone temperature is equal to or less than the Active Heating Temperature Setpoint. The control reenters the Deadband mode when the zone temperature is 1 °F greater than the Active Heating Temperature Setpoint and the calculated Heating Requirement is equal to zero.

Active Temperature Setpoints

The controller maintains the zone temperature between Active Cooling and Heating Temperature Setpoints. The Active Cooling and Heating Temperature Setpoints are based on Control State, the Active User Adjust based on the position of the Slide Switch or Variable User Adjust, and the Active Demand Limit Reset.

If Half Degree Enable is set then the Temperature Setpoints are in half-degree (Fahrenheit or Celsius) increments.

If User Adjust Enable is set, the Active Temperature Setpoints may be modified by the variable user adjust potentiometer on a WS-0XX wall sensor. The Active Heating Temperature Setpoint is adjusted up and the Active Cooling Temperature Setpoint is adjusted down a fraction of the User Adjust Setpoint. If the WS-051 is used then the setpoints are adjusted with up and down arrows with in user defined limits.

If the Active Demand Level is non-zero, the Active Temperature Setpoints are also modified by a fraction of the Demand Reset Range as the Active Demand Level goes from 0 to 6. The Active Cooling Temperature Setpoint is reset upwards and the Active Heating Temperature Setpoint is reset downwards.

Cooling and Heating Requirement

In Deadband Control Mode, the Heating and Cooling Requirements are zero.

In the Cooling or Heating Control Mode, the Cooling or Heating Requirement is calculated using a PI control loop.

The change in heating or cooling requirement is calculated every 30 seconds.

$$\text{In heating: Error} = \text{Active HTG SP} - \text{Zone Temp}$$

$$\Delta \text{ Error} = \text{Previous Zone Temp} - \text{Zone Temp}$$

$$\text{or in cooling: Error} = \text{Zone Temp} - \text{Active CLG SP}$$

$$\Delta \text{ Error} = \text{Zone Temp} - \text{Previous Zone Temp}$$

$$\Delta \text{Requirement} = (100\% / \text{ThrottleRange}) * [\text{Error} * (\text{CalcTime} / \text{Int Time}) + \Delta \text{Error}]$$

The factory setting for throttle range is 4.0 degrees, and for integral time is 2.5 minutes.

Primary Airflow Modulation

In the Cooling Mode the primary airflow modulates between the Active Cooling Minimum and Maximum Airflow Setpoints as the cooling requirement goes from zero to 100 %.

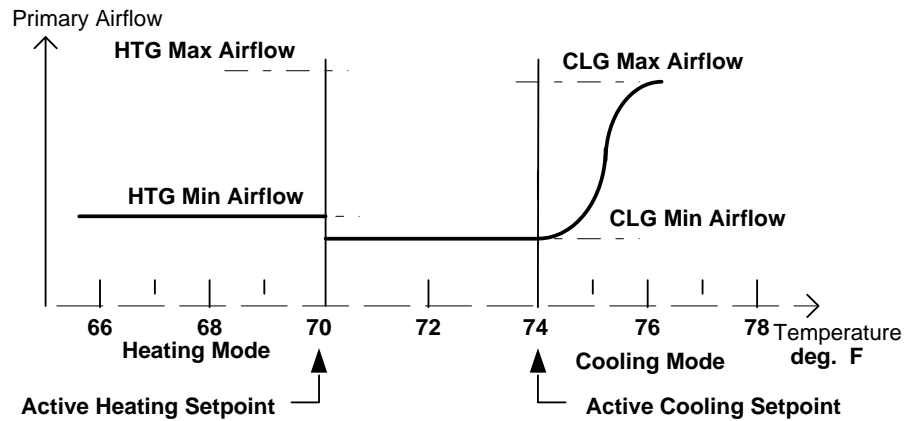

In the Deadband Mode the Primary Airflow is typically at the Active Cooling Minimum Airflow Setpoint.

In the Heating Mode the Primary Airflow is at the Active Heating Minimum Airflow Setpoint and the Local Heat is modulated to maintain the Active Heating Temperature Setpoint. If Dual Heating Enable is set then the primary airflow also modulates between Heating Minimum and Maximum Airflow as the heating requirement goes from 0 to 100%.

Pressure Dependent Operation

If Pressure Dependent Enable is yes, then the position of the Primary Damper motor is controlled based on Damper Drive Time rather than airflow. The Cooling and Heating Damper Minimum and Maximum Positions are a percentage of the Damper Drive Time.

In the Cooling Mode the damper modulates between the Active Cooling Damper Minimum and Maximum Positions as the zone Cooling Requirement goes from zero to 100 %.

In the Deadband Mode the damper is typically at the Active Cooling Damper Minimum Position.

In the Heating Mode the damper is at the Active Heating Damper Minimum Position and the Local Heat is modulated to maintain the Active Heating Temperature Setpoint. If Dual Heating Enable is set then the damper also modulates between Heating Minimum and Maximum Airflow as the heating requirement goes from 0 to 100%.

To maintain indexing of damper position the Damper is driven fully closed for a Damper Drive Time: On reset of Power, On return from Damper Override, or Emergency Mode.

Control State

The Control State determines which Cooling and Heating Temperature Setpoints are used for zone temperature control. Four control states are possible: Occupied, Unoccupied, Night Setback, and Morning Warm-up. If the Clock is not synchronized, the Control State is Occupied by default. Otherwise the Control State is determined by the Daily Event Schedule.

The Control State may be overridden via a message broadcast over the communication bus from software or an ASIC/2 controller. The controller state may be returned to OCC from NSB or Unocc when the Afterhours Enable is yes and the push-button on the Wall Sensor is pushed.

The Active Cooling and Heating Minimum and Maximum Airflow Setpoints are typically given by the Occupied Cooling and Heating Minimum and Maximum Airflow Setpoints.

However, if Multiple Airflow Enable is set, the Active Cooling and Heating Minimum and Maximum Airflow Setpoints are given by: the Occupied Cooling and Heating Minimum and Maximum Airflow Setpoints in the Occupied and Morning Warm-up States; the Unoccupied Cooling and Heating Minimum and Maximum Airflow Setpoints in the Unoccupied State; or the Night Setback Cooling and Heating Minimum and Maximum Airflow Setpoints in the Night Setback State.

Deadband Mode

In the Deadband Mode, the operation of the primary air damper (and the fan if any) depends on the Control State and option selections.

In Occupied Deadband the Primary Airflow is at the Active Cooling Minimum Airflow Setpoint.

In Unoccupied Deadband the Primary Airflow is at the Active Cooling Minimum Airflow Setpoint, unless UNO Option 2 Enable is yes, then the primary air damper is closed (and the fan if any is OFF) in Deadband.

In Night Setback Deadband Mode the primary Airflow is at the Active Cooling Minimum Airflow Setpoint, unless NSB Option 2 Enable is yes, then the primary air damper is closed (and the fan if any is OFF) in Deadband.

Primary Damper Control - Intermittent Fan

	Occupied	Changeover	UNOCC Option 2 = No	UNOCC Option 2 = Yes	NSB Option 2 = No	NSB Option 2 = Yes	MWU Option 2 = No	MWU Option 2 = Yes
Cooling	Modulate	Min CLG	Modulate	Modulate	Modulate	Modulate	Min HTG	Min HTG
Deadband	Min CLG	Min HTG	Min CLG	Closed	Min CLG	Closed	Min HTG	Min HTG
Heating	Min HTG	Modulate	Min HTG	Min HTG	Min HTG	Min HTG	Max HTG	Min HTG

Morning Warm-up (MWU) State

Morning Warm-up is meant as a prelude to Occupied state, to ready the building for daily use. For Morning Warm-up, the control sequence operates at full-capacity heating until the zone temperature is moved into the Deadband region.

Two MWU sequences can be selected: central heating, and local heating. In central heating MWU hot air is distributed through the primary air ducts. In local heating MWU, all heat is provided from the VAV terminal.

MWU, Central Heating

If Morning Warm-up Option 2 Enable is not set then central heating is assumed where hot air is in the duct as in changeover heating, which is described below. If the control is initially in cooling or heating mode, the opposite mode is locked-out until the end of Morning Warm-up.

All local heat is typically OFF during this sequence. However if Local Heat Enable is yes, then local heat is used in addition to central heat.

Morning warm up differs from changeover because the controller goes into heating once, while in changeover it can go in and out of the heating mode many times.

MWU, Local Heat

If Morning Warm-up Option 2 Enable is set then local heating is assumed. The airflow is maintained at Occupied Heating Minimum Airflow Setpoint and all heating is provided by local hot water or electric heat.

August 2009

If zone temperature is less than Occupied Heating Setpoint when the control enters MWU state, the heating requirement is 100%, the local hot water or electric heat is at 100%.

When zone temperature reaches Occupied Heating Temperature Setpoint the heating requirement is at 0% and the heat turns OFF. If the zone temperature falls 2 °F below the Occupied Heating Temperature setpoint, the heating requirement is again at 100% to maintain temperature setpoint. This cycle continues while in MWU state.

Changeover

A changeover feature is available which modifies the modes of operation in Heating, Deadband, and Cooling Control Modes. In changeover it is assumed that the primary supply air temperature is appropriate for heating. Changeover is useful for applications where a single duct serves both heating and cooling at different times.

In the changeover heating mode, the Active Primary Minimum and Maximum Airflow setpoints are given by the Active Heating Minimum Airflow and Heating Maximum Airflow Setpoints. The airflow modulates based on the zone Heating Requirement.

In changeover Deadband the supply air is maintained at Active Heating Minimum Airflow Setpoint.

In changeover cooling the airflow is maintained at the Active Cooling Minimum Airflow Setpoint.

An option Local Heat Enable, if set allows local heat to come on in addition to central heat whenever the controller is operating in changeover.

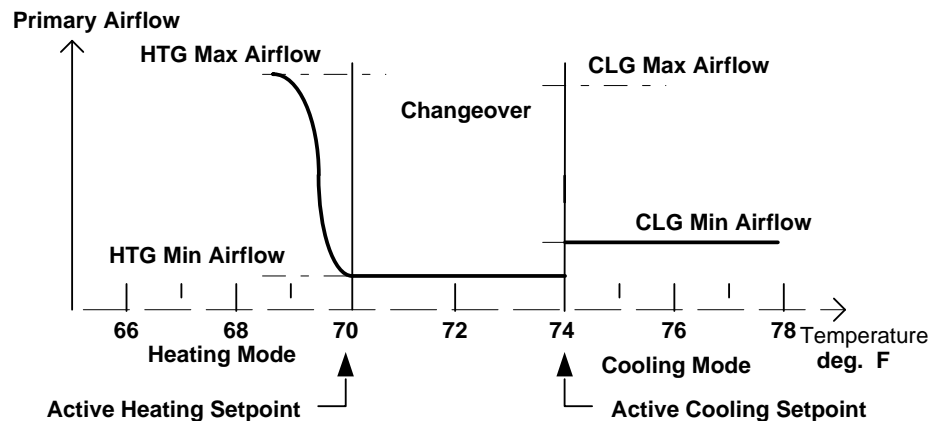

Auto-changeover

Auto-changeover requires installation of a supply air temperature sensor on input 6. If the measured supply air temperature is greater than the Changeover Setpoint, the controller goes into a heating only changeover mode. If the Changeover Setpoint is 0 F (default), the auto-changeover feature is disabled.

Remote Changeover

A remote command on the communications line to set changeover ON forces the system to control in the changeover heating mode. A remote command to set changeover OFF forces prevents all changeover control action. Remote commands always take priority over auto-changeover. A remote command to restore changeover clears changeover ON and changeover OFF and enables the auto-changeover control action.

Pressure Dependent Changeover

In changeover it is assumed that the primary supply air temperature is appropriate for heating.

If Pressure Dependent Enable is yes, then in changeover heating, the damper modulates between the Active Heating Damper Minimum and Maximum Positions based on the zone Heating Requirement.

If Local Heat Enable is set, the local heat also comes on in addition to central heat whenever the controller is operating in changeover heating.

In changeover Deadband the supply air is maintained at Active Heating Damper Minimum Position.

In changeover cooling the airflow is maintained at the Active Cooling Damper Minimum Position.

Outputs

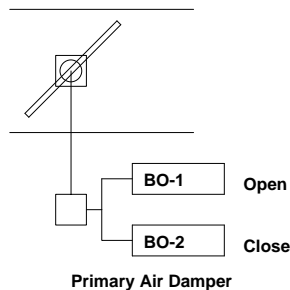

Primary Air Damper

In Single Duct personalities in Cooling Control mode, the controller modulates the Primary Airflow Setpoint between the Active Cooling Minimum and Maximum Airflow setpoints based on the Cooling Requirement.

The Primary Airflow is compared with the Primary Airflow Setpoint every a second. As the damper drives the airflow toward the setpoint, the output begins to pulse, where the pulse size in 1/6 s increments is given by $4 * \text{Airflow Error} / \text{AF Hysteresis}$. The smallest non-zero Airflow Hysteresis gives the fastest approach to setpoint.

As control approaches the setpoint, the airflow error is summed over time. The Airflow Integration Time [Default 4] is the time required for a 25 ft/min error to sum to give an additional pulse. To enable this algorithm you must give the Airflow Integration Time [Default 4] a non-zero value. If Airflow Integration Time is zero, then it drives to the Airflow Setpoint, and waits until airflow exceeds hysteresis.

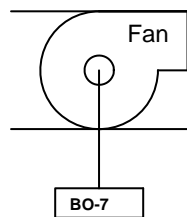

Intermittent Fan

For Parallel Fan Powered Terminal box control, the intermittent fan is based on the operating state, mode, and whether the supply airflow is greater than the **Fan Energize Setpoint**.

In Deadband the fan is on or off depending on the sequence selected.

The fan is ON whenever the primary airflow is less than or equal to the **Fan Energize Setpoint**. If Ifan Heating Only Enable is true, the fan is on ONLY in the heating mode independent of the Fan Energize Setpoint.

- o In the occupied state, the fan is on only if the supply airflow is less than the Fan Energize Setpoint.
- o In the morning warm up state, the fan is on.
- o In night setback or unoccupied states, the fan is off unless the system is in heating mode and the supply airflow is less than the Fan Energize Setpoint.
- o In Emergency 1 the Fan is overridden On. In Emergency 2 the Fan is overridden Off.

Intermittent Fan Control

(* Primary Airflow < Fan Energize SP)

	Occupied	UNOCC Option 2 = No	UNOCC Option 2 = Yes	NSB Option 2 = No	NSB Option 2 = Yes	MWU Option 2 = Yes or No
Cooling	Fan On*	Fan Off	Fan Off	Fan Off	Fan Off	Fan On

Deadband	Fan On*	Fan Off	Fan Off	Fan Off	Fan Off	Fan On
Heating	Fan On*	Fan On*	Fan On*	Fan On*	Fan On*	Fan On

Electric Heat Output

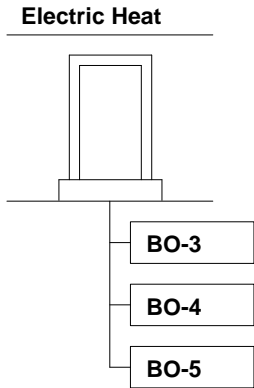

Up to 3 stages of Electric Heating output may be used to maintain the calculated heating requirement in personalities 6, and 78.

For a controller with 1 stage of electric heat (Personality 2,6,9): Stage 1 duty cycles in proportion to the Electric Heat Base Time; from 0 to 100% as the Heating Requirement goes from 0 to 100%.

For a controller with 2 stages of electric heat (Personality 3,7,10): Stage 1 duty cycles in proportion to the Electric Heat Base Time from 0 to 100% as the Heating Requirement goes from 0 to 50%; and Stage 2 does not turn ON until stage 1 is on for 100% of the duty cycle time and duty cycles in proportion to the Electric Heat Base Time from 0 to 100% as the Heating Requirement goes from 50% to 100%.

The output to be controlled is identified by the Electric Heat 1,2 Masks . The functional status of the Electric Heat Outputs is shown by the Electric Heat 1,2 Output Status bits.

Hot Water Heat Output

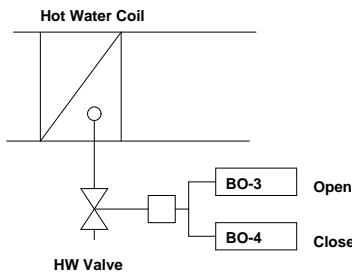

In a controller with modulated hot water heat (Personality 5, 12, or 13), the valve is opened or closed a fraction of the HW Valve Base Time in proportion to the Heating Requirement. The output to be controlled is identified by the HW Valve Open Mask [Default; BO-3] and HW Valve Closed Masks[Default; BO-4]. The functional status of the HW Valve output is shown by the HW Valve Output Status.

For a controller with modulated hot water heat , the valve is opened or closed a fraction of the valve time base in proportion to the Heating Requirement based on the five-value Heating Valve Output Table.

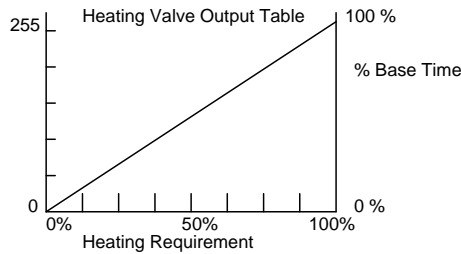

Thermic Valve On/Off (Optional)

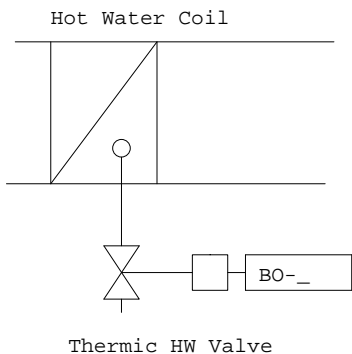

The output to be used is assignable using the Thermic Valve On/Off Mask.

In a controller with thermic valve hot water heat (Personality 18, 19, or 20), the valve is energized for a fraction of the HW Valve Base Time in proportion to the Heating Requirement. The thermic Valve is normally off and will be ON for a fraction of the HW Heating Base Time. It will be initially on and once it goes off it stays off for the remainder of the HW Heating Base.

$$\text{Timer On Time} = (\text{HW Output}/255) * \text{HW Base Time}.$$

If Thermic Valve Reversed is set the output will be normally on, and will be OFF for a fraction of the HW Heating Base Time.

Other Outputs

Analog Output (Optional)

An Analog Output, 0 to 10 Vdc at up to 20 mA is provided which optionally may be assigned to track the Heating or Cooling Requirement [Default; Heating]. The output goes from Minimum Output Voltage to Maximum Output Voltage as the Requirement goes from 0 to 100 %.

Auxiliary Cooling Output (Optional)

An optional auxiliary cooling output is provided. If Auxiliary Cooling Enable is set, and the Cooling Requirement is 100 % and the zone temperature exceeds the active cooling setpoint by an Auxiliary Cooling Offset [Default 2 oF] for a Auxiliary Cooling Delay Time [Default: 120 s], then an auxiliary cooling output is energized. The output to be used is assignable using the Auxiliary Cooling Output Mask [Default: Output #5]. Once energized, the auxiliary cooling output remains on until the zone temperature falls below the active cooling temperature setpoint, and the cooling airflow falls below the maximum cooling setpoint by an amount given by the Auxiliary Cooling Hysteresis. [Default: 125 ft/min]

Auxiliary Heating Output (Optional)

If Auxiliary Heating Enable is set, the auxiliary heating output goes on whenever the controller is in the heating mode. This output is completely independent of the hot water valve or electric heat operation. It may be used to control baseboard heat used in conjunction with terminal boxes.

Auxiliary 1, 2, 3 Output (Optional)

The ASIC/1-6000 allows up to 3 outputs for auxiliary outputs which do not follow any schedule. They can be overridden On or Off, and remain in the last state commanded. The output to be controlled is identified by the Aux 1, 2, 3 Masks which are initially unassigned.. The functional status of the Aux 1, 2, 3 Outputs is shown by the Auxiliary 1, 2,3 Output Status.

Lighting Output

Each ASIC/1 has the ability to control lighting. The Lights Output Mask [Default: None] must set to an unused binary output. The Lighting schedule will automatically turns the lights on and off. By equipping the ASIC/1 with a WS-0XX wall sensor with push button override, the lights can be operated manually by the occupant during Occupied and Morning Warm-up States by pressing the button on the side of the zone sensor without affecting HVAC operation.

During Unoccupied and Night Setback States, depressing the push button will return the control to Occupied, and the lights will come on and stay on for Afterhours Time Allowed. During Emergency 1 and Emergency 2, the push-button has no effect.

If Lights Occupied Enable is yes then the lights are on whenever the Lighting Schedule is On, or the Control State is occupied.

Blink Warning: One minute before automatic shut off of lights as designated in the daily event schedule, or at the end of the afterhours override period, the lights will blink off and back on again. Pressing the afterhours button will re-start the lights.

Alarms

Zone Temperature Alarm

If the zone temperature is above the Active Cooling Temperature Setpoint by the Zone Temperature Alarm Range, a High Zone Temperature Alarm is set. If the Zone temperature is below the Active Heating Temperature Setpoint by the Zone Temperature Alarm Range, a low Zone Temperature Alarm is set. No other actions are taken in response to a zone temperature alarm.

Primary Airflow Alarm

If the primary airflow is above the Primary Airflow Setpoint by the Airflow Alarm Range, then a High Primary Airflow Alarm is set. If the Primary Airflow is below the Primary Airflow Setpoint by the Airflow Alarm Range, then a Low Primary Airflow Alarm is set. No other actions are taken in response to a primary airflow alarm.

Emergency Modes

The emergency modes, Emergency 1, and Emergency 2, are overrides which are received over the communication line and remain in effect until cleared over the communication line.

Emergency 1 Mode

The control may only enter or exit Emergency 1 as a result of commands received on communications line. While in Emergency 1, no other state may be entered until Emergency 1 has been cleared via the communications line. Emergency is maintained through loss of power.

While in Emergency 1 state the controller immediately drives the damper to Maximum Cooling Airflow Setpoint, turns ON the lighting output, and turns OFF any other outputs including electric heat. In EM1 the Fan is On.

Emergency 2 Mode

The control can enter and exit Emergency 2 as the result of commands received on the communications line. If in Emergency 2, no other state except Emergency 1 may be entered until Emergency 2 has been cleared via the communications line. Emergency is maintained through loss of power.

While in Emergency 2 state the controller immediately drives the damper closed, turns ON the lighting output and turns OFF any other outputs, including electric heat.

Communications

The ASIC/1-6000 communicates at 1200 baud, 9600 baud, or 19,200 baud on the remote bus using RS-485 twisted pair communication wire, connected to remote screw terminal connector, TB-4. Access to the ASI communication bus is through a SINC/3-3000 system interface or ASIC/2 configurable controller which can also be used to broadcast time to synchronize the network of ASIC/1 controllers.

Communication with the remote bus can also be established through the WS-0XX wall sensor using a SINC/1-1030 Portable Interface connected to a lap-top computer running ASI Expert Software. It can also communicate through the WT-0XX in the remote communication mode. The local communication mode is not supported.

August 2009

Communication with the remote bus can also be established through the WS-0XX wall sensor using a SINC/1-1030 Portable Interface connected to a lap-top computer running ASI SET-8055 Setup Software. It can also communicate through the WT-0XX in the remote communication mode. The local communication mode is not supported.

Each controller has a unique 16 bit address, and may also have a separate 8 bit group address. It will also respond to the global addresses 23125 (5A55h) and 23130 (5A5Ah).

The ASIC/1-6000 may co-exist on the communication line with other ASIC/1 controllers. It is compatible with the ASI LinkOPC Server for seamless communication with Windows based graphic user interfaces.

System Component Checklist

Inputs

Description	Part Number	Quantity
AF-001 Airflow Filter)	Included	
Optional Duct Temperature Sensor (IN-05)	TS-DO-8	0,1
Optional Duct Temperature Sensor (IN-06)	TS-DO-8	0,1
Wall Mounted Zone Temperature Sensor	WS-0X1	1
Sensor Cable	SCP-0XX	1
Communication Cable twisted pair.	22-24 ga twisted	

NOTE: Consult ASIC/1-6000 Installation manual for configuration of inputs.

Outputs

Description	Part Number	Quantity
VAV Controller	ASIC/1-6000	1
24 Vac Transformer		1
24 Vac Tri-state Primary Damper Operator		1
24 Vac Fan Control Relay		1
HW Valve with 24 Vac Tri-state Operator		0,1
24 Vac Thermic Valve (Optional)		0,1
24 Vac Electric Heat Relay		0,1,2
24 Vac Auxiliary CLG Output Relay (Optional)		0,1
24 Vac Auxiliary HTG Output Relay(Optional)		0,1
24 Vac Auxiliary Output Relay (Optional)		0,1,2,3
24 Vac Lighting Relay (Optional)		0,1

NOTE: . The ASIC/1-6000 must be connected to a solid building ground. Metallic-oxide Varistors, MOV, are used across triac outouts to provide further protection from transients. If current interrupting relays are in series with the output circuits they must be protected with MOVs across the Relay Contacts

Wiring Layout

Intermittent VAV with 2 Stages of Electric Heat

Intermittent Fan Powered VAV with up to 2 Stages of Electric Heat, for use with the following personalities: Personality 16, cooling only; Personality 6, 1 stage of electric heat; or Personality 7, 2 stages of electric heat.

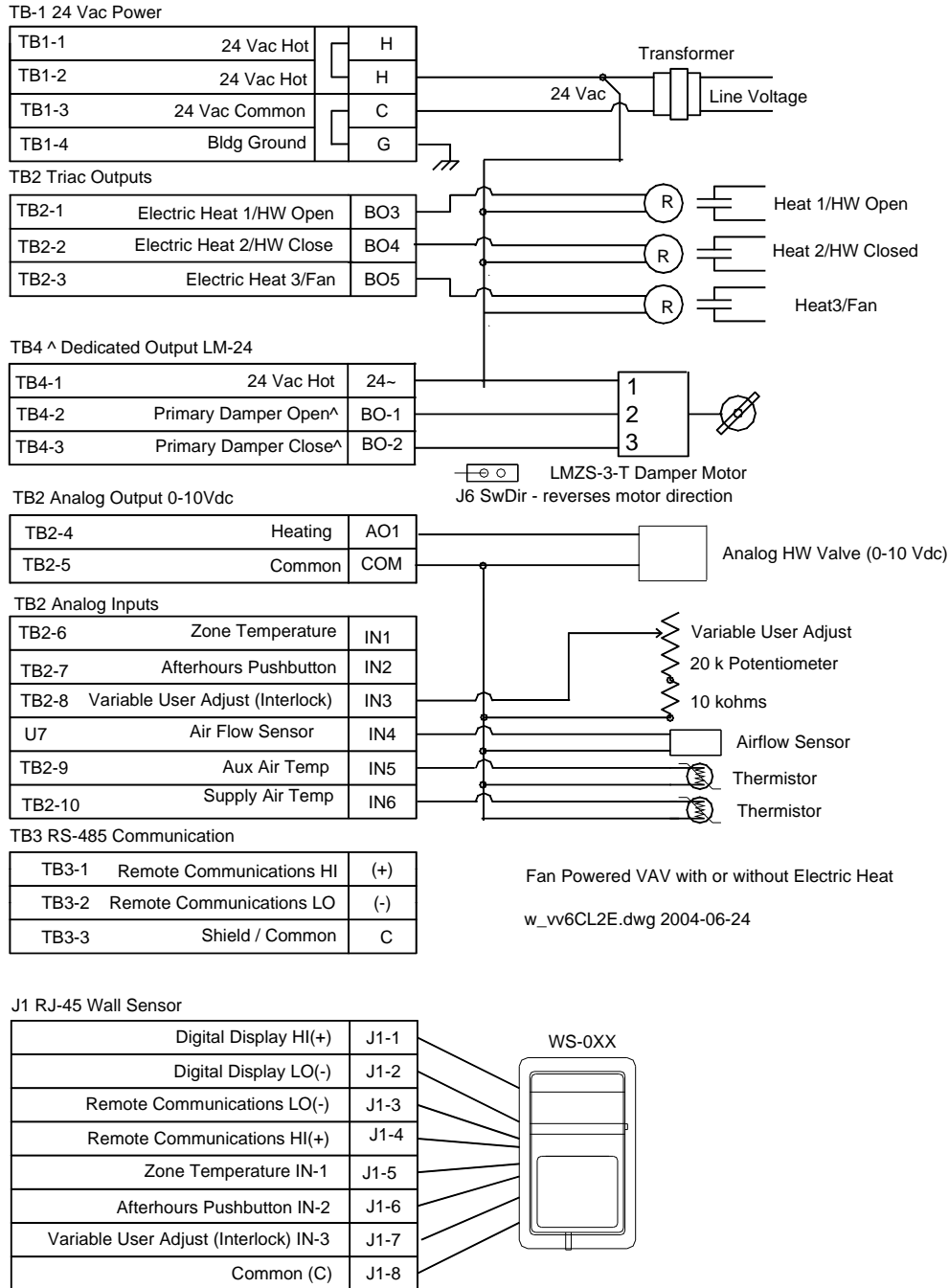

Intermittent Fan with Hot Water Heat

Typical Intermittent Fan Powered VAV with Hot Water Heat for Personality 12.

