



## Temperature Sensors

### TS Series Options

- Temperature via thermistor  
3 kohm @ 77 °F (25 °C)
- Duct Insertion
- Immersion with Well
- Duct Averaging
- Strap-on
- Outside Air Temperature
- Flying leads for easy wiring

### Product Specifications

Output: 3,000 Ohms @ 77 °F (25 °C)

Temperature Range:

-40 to 100 °C

-40 to 212 °F

Interchangeability:

0.2 degrees C (0 to 70 °C)

Highly Stable, No Field Calibration Required

Dissipation Constant:

3 mW per degree Celsius

Connections: flying leads.

The TS Series

temperature sensors are thermistor type sensors. They may be used with the ASIC/1-8x55, and ASIC/2 products that include conversion tables for these. These sensors are a perfect complement to the WS-R and WS-0xx series. The TS Series temperature sensors are offered with options including: Duct Insertion, Immersion, Averaging, Strap-on, and Outside Air Temperature.

**TS-D-x** Duct Insertion temperature sensors with J-box where x is the length 4", 8", 12", or 18". Sensor is mounted through hole in duct and attached with mounting bracket.

**TS-I-x** Immersion temperature sensors (including 304 series stainless steel thermowell 1/2" NPT thread) where x is the length 4" or 8".

**TS-A-x** Averaging temperature sensors where x is the length 8 ft, 12 ft, or 24ft. The sensor is inserted through hole in duct, and then strung in a fashion that covers the greatest surface area.

**TS-S** Strap-on temperature sensors includes junction box. Mounted on bottom side of pipe with 2"-5" pipe clamp.

**TS-O** Outside Air Temperature sensor in weatherproof enclosure with mounting hardware. Mount downward and out of direct sunlight.

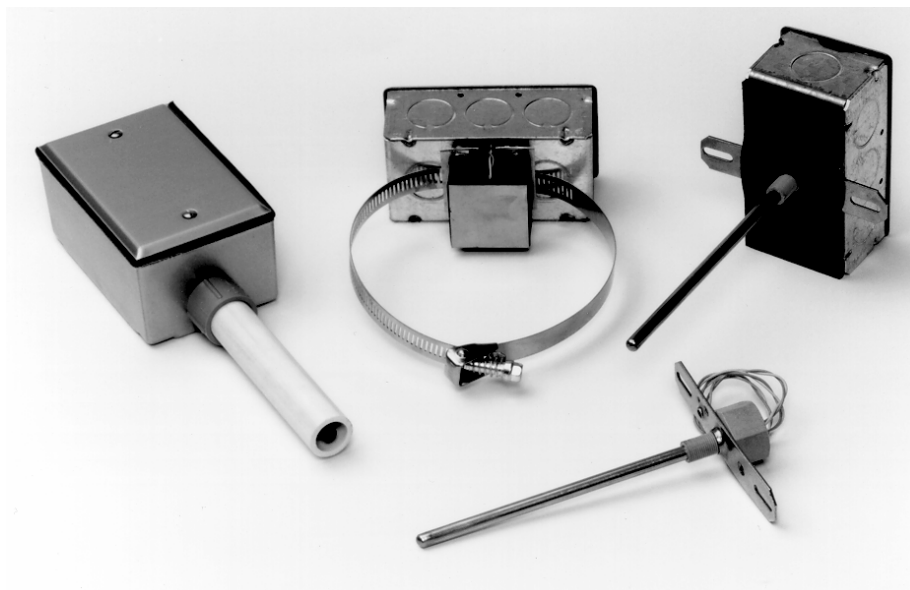

Temperature Sensors



### Dimensions

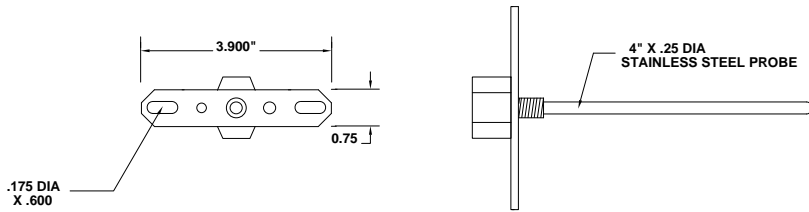

Duct/Immersion sensor shown without box.

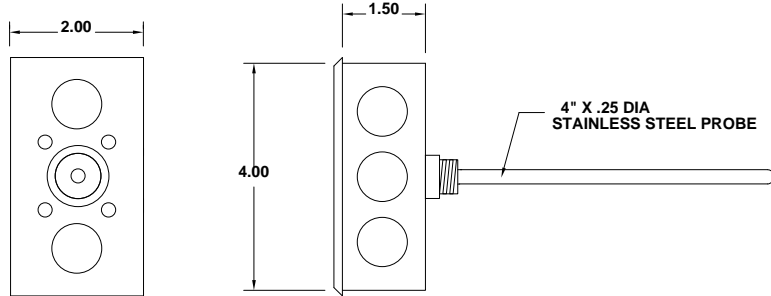
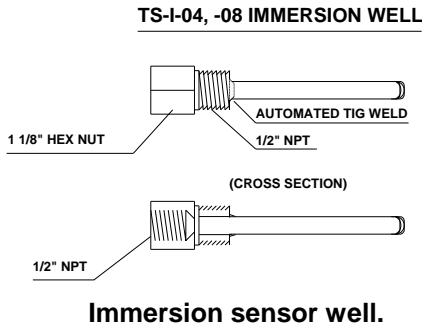

Duct/Immersion sensor shown with box.

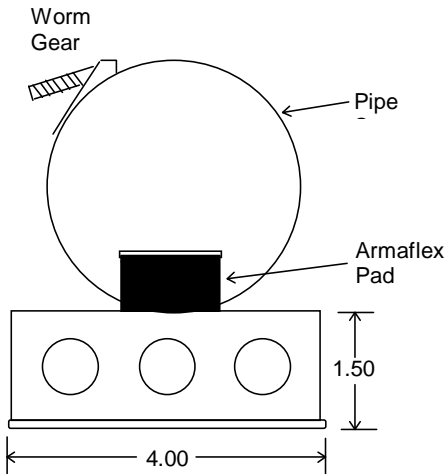

**TS-S, Strap-on sensor.**

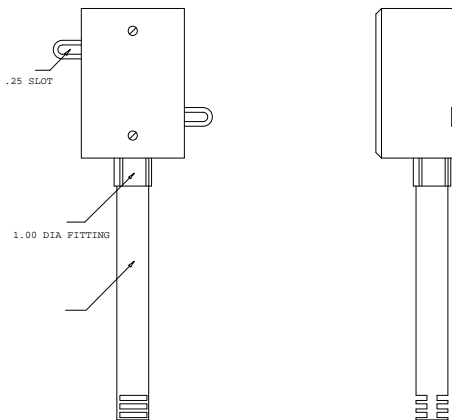

**TS-O, Outside Air Sensor.**

How to Order:	Order Number
Duct Insertion Temperature Sensor Length 4 inches Length 8 inches Length 12 inches Length 18 inches	TS-D-04 TS-D-08 TS-D-12 TS-D-18
Immersion Temperature Sensor Length 4 inches Length 8 inches	TS-I-04 TS-I-08
Averaging Temperature Sensor Length 8 ft Length 12 ft Length 24 ft	TS-A-08 TS-A-12 TS-A-24
Strap-On Temperature Sensor	TS-S
Outside Air Temperature	TS-O



**Made in USA**