

# Dual Duct VAV

## Application

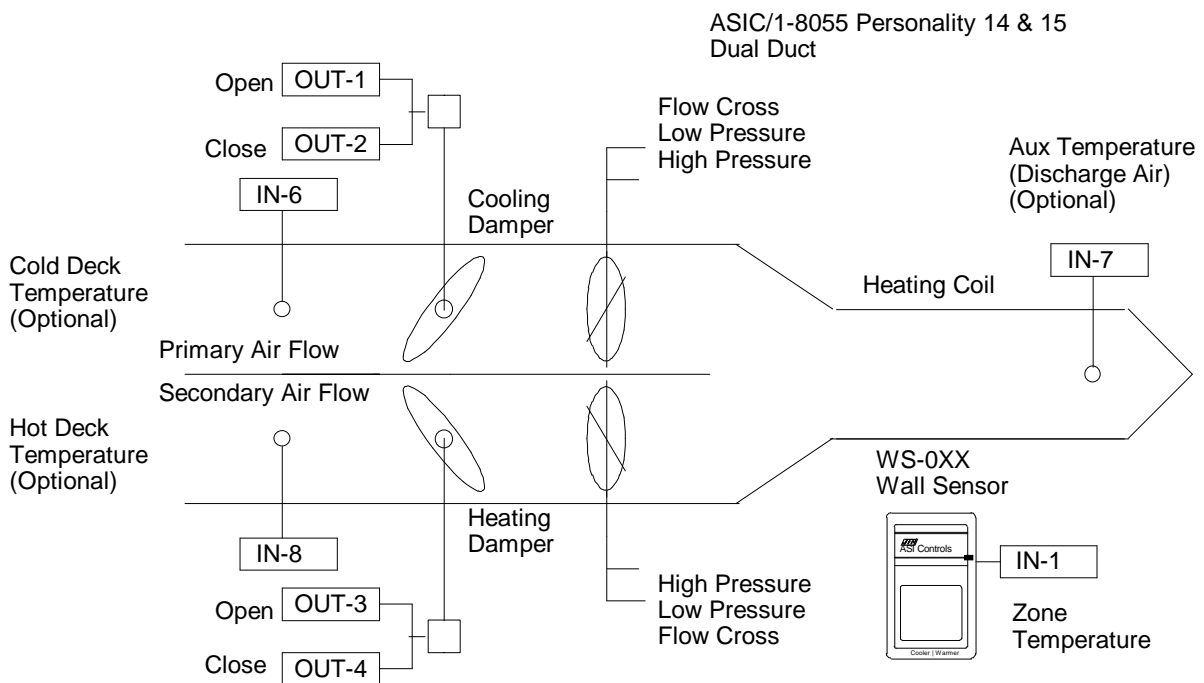

This application bulletin describes the sequence of operation used by the ASIC/1-8055 to control zone temperature with a dual duct VAV system with or without blending. The ASIC/1-8055 uses an primary airflow sensor to give pressure independent control of the variable air volume cooling. It uses an secondary airflow sensor to give pressure independent control of the variable air volume heating. If the blending personality is selected, then the cooling and heating airflow are modulated, so that a minimum total airflow is maintained. The ASIC/1-8055 is preprogrammed with two dual duct personalities.

### Dual Duct Personalities

	Without Blending	With Blending
Dual Duct	14	15

## Inputs

The ASIC/1-8055 controller has specific inputs for zone temperature, primary cooling airflow, and secondary heating airflow, and optional supply air temperature, and optional occupancy sensor. The default input types are set at the factory. Inputs that are not required for the sequence may be used for monitoring.

### Primary Airflow

The ASIC/1-8055 uses an primary airflow sensor to give pressure independent control of the cooling air volume. The primary airflow sensor is installed on input 4 in the pin-sockets at AIR1. It is calibrated at zero airflow.

The controller measures the air velocity in feet per minute (ft./min) assuming a standard velocity K-factor of 2338 ft/min. The velocity K-factor is the air velocity in ft/min required to generate a velocity pressure of 1 inch water column (1 "wc =249 Pa) The velocity K-factor is provided by the VAV box manufacturer for a particular box size and flow cross. The airflow volume Q in CFM is calculated based on the actual K-factor in feet per minute , and duct area in square feet.

$$Q \text{ (CFM)} = \text{Area (ft}^2\text{)} * \text{Velocity(ft/min)} * (\text{K-factor}/2338)$$

Field calibration of the velocity K-factor can be done by the air balancer using the air balance screen on the Setup software.

Note: Both airflow sensors require an airflow filter, AF-001, on the high pressure side, to prevent dust from contaminating the sensor. The High and Low pressure sides are opposite to that of the ASIC/1-8015 controller!

### Secondary Airflow

The secondary airflow is required for dual duct personalities. The secondary airflow sensor is used with a properly positioned airflow cross to control the heating air volume. A secondary airflow sensor may installed on input 5 in the pin-sockets at AIR2. It is calibrated at zero airflow and has separate K-factors and duct areas.

### Wall Sensor Connections

Zone temperature sensor is normally on input 1. Typically, the zone temperature on the WS-0xx, or WT-0XX wall sensor, is connected to the controller using a SCP-XXX sensor cable sensor. Alternately, a zone or return air temperature sensor may be attached on input blade, IN1. If there is no zone temperature sensor , then the zone sensor input is in fault, all outputs are off, and it does not try to control.

The afterhours push-button on the WT-0XX, or WS-0X1 wall sensor if used, is always on input 2. If Afterhours Enable is Yes, then shorting the input to zero will initiate afterhours override mode for an Afterhours Time Allowed.

Input 2 may be used for the user adjust switch on the WT-0XX Wall Sensor . When User Adjust Enable is set and input 2 is configured for user adjust switch, the zone temperature setpoint may be adjusted up or down by the User Adjust Setpoint, based on the condition of Input 2.

Input 3 is used for Interlock and may be used for variable user adjust with the WS-0XX wall sensor. When User Adjust Enable is set and input 3 is configured for Variable User adjust, 10k to 30 kohm, the zone temperature setpoint may be adjusted up or down by the User Adjust Setpoint, based on the condition of input 3.

## Auxiliary Temperature Sensors

An optional a duct temperature sensor, TS-DO, may be placed on input 6, 7, or 8 for temperature monitoring. The auxiliary temperature sensors use the factory provided 1.82 kohm pull-up resistor.

An optional occupancy sensor or switch may be used on input 8 to change the control state from occupied to unoccupied. When the occupancy sensor is used in combination with a temperature sensor, then the temperature sensor is not read when the contacts are closed.

## Control Mode

The controller determines the Control Mode, Heating, Deadband, or Cooling by comparing the zone temperature to the Active Heating Temperature Setpoint and Active Cooling Temperature Setpoint.

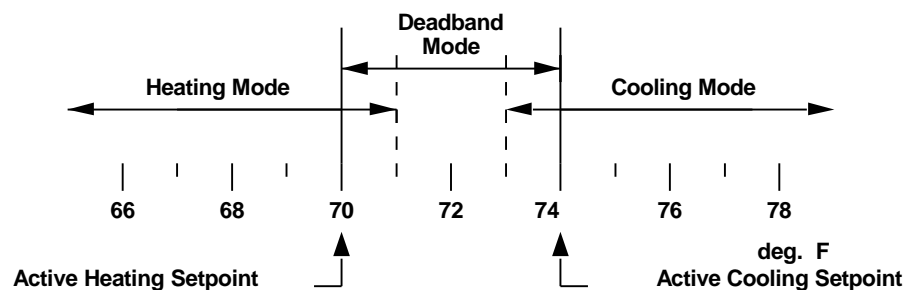

The controller enters the Cooling Control Mode when the zone temperature equals or is greater than the Active Cooling Temperature Setpoint. The control reenters the Deadband mode, when the zone temperature is 1 °F below the Active Cooling Temperature Setpoint and the calculated Cooling Requirement is equal to zero.

The control enters the heating mode when the zone temperature is equal to or less than the Active Heating Temperature Setpoint. The control reenters the Deadband mode when the zone temperature is 1 °F greater than the Active Heating Temperature Setpoint and the calculated Heating Requirement is equal to zero.

## Active Temperature Setpoints

The controller maintains the zone temperature between Active Cooling and Heating Temperature Setpoints. The Active Cooling and Heating Temperature Setpoints are based on Control State, the Active User Adjust based on the position of the User Adjust Switch or Variable User Adjust, and the Active Demand Limit Reset.

If User Adjust Enable is set, the Active Temperature Setpoints may be modified either by the User Adjust Switch on a WT-0XX wall sensor, or by the variable user adjust potentiometer on a WS-0XX wall sensor depending on the input configuration. The Active Heating Temperature Setpoint is adjusted up and the Active Cooling Temperature Setpoint is adjusted down a fraction of the User Adjust Setpoint.

If the Active Demand Level is non-zero, the Active Temperature Setpoints are also modified by a fraction of the Demand Reset Range as the Active Demand Level goes from 0 to 6. The Active Cooling Temperature Setpoint is reset upwards and the Active Heating Temperature Setpoint is reset downwards.

## Cooling and Heating Requirement

In Deadband Control Mode, the Heating and Cooling Requirements are zero.

In the Cooling or Heating Control Mode, the Cooling or Heating Requirement is calculated using a PI control loop.

The change in heating or cooling requirement is calculated every 30 seconds.

$$\begin{aligned} \text{In heating: Error} &= \text{Active HTG SP} - \text{Zone Temp} \\ \Delta \text{Error} &= \text{Previous Zone Temp} - \text{Zone Temp} \end{aligned}$$

$$\begin{aligned} \text{or in cooling: Error} &= \text{Zone Temp} - \text{Active CLG SP} \\ \Delta \text{Error} &= \text{Zone Temp} - \text{Previous Zone Temp.} \end{aligned}$$

$$\Delta \text{Requirement} = (100\% / \text{ThrottleRange}) * [ \text{Error} * (\text{CalcTime} / \text{Int Time}) + \Delta \text{Error} ]$$

The factory setting for throttle range is 4.0 degrees, and for integral time is 2.5 minutes.

## Cooling Airflow Modulation

When in the cooling mode the controller modulates Primary Airflow Setpoint is modulated between the Active Cooling Minimum and Maximum Airflow Setpoints as the Cooling Requirement goes from zero to 100 %.

If blending is used (personality 15) in the Cooling Mode, the heating airflow is modulated so that the total delivered airflow does not fall below the Total Minimum Airflow Setpoint. If blending is not used (personality 14) the heating damper is CLOSED.

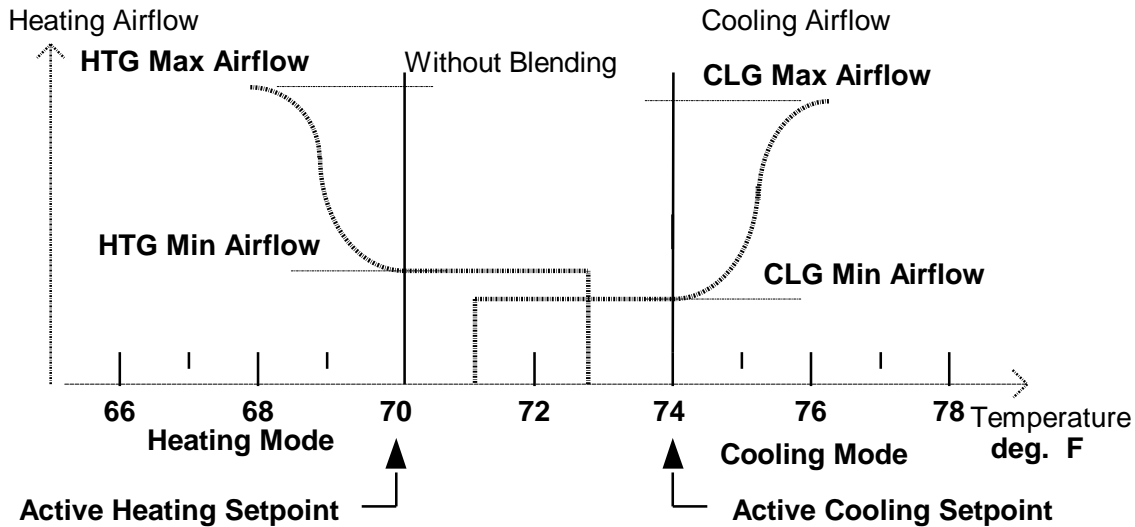

## Heating Airflow Modulation

When in the heating mode the controller modulates Secondary Airflow Setpoint is modulated between the Active Heating Minimum and Maximum Airflow Setpoints as the Heating Requirement goes from zero to 100 %.

If blending is used (personality 15) in the heating mode the cooling airflow is modulated so that the total delivered airflow does not fall below the Total Minimum Airflow setpoint. If blending is not used (personality 14) the cooling damper is CLOSED.

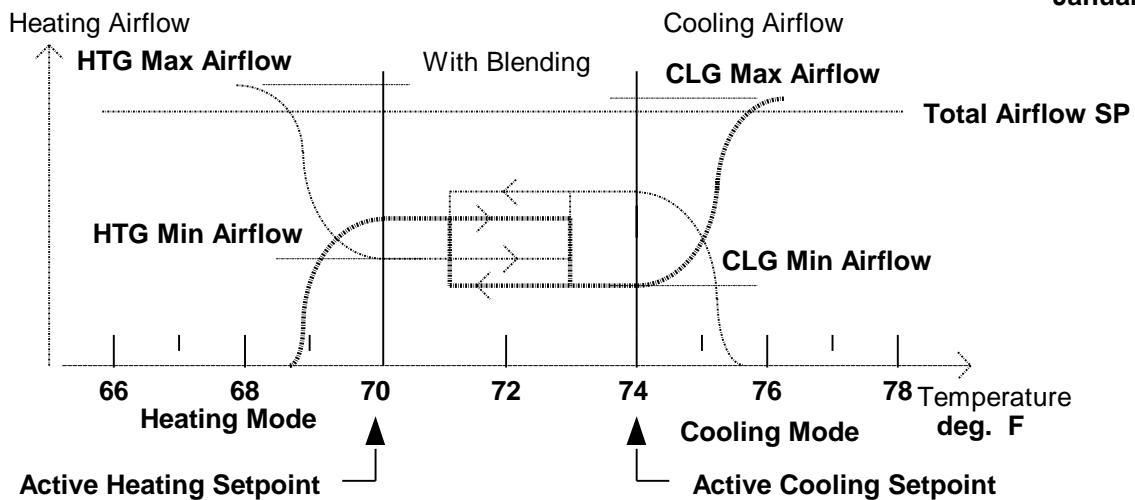

## Deadband Airflow Modulation

In Deadband Control Mode, the controlling airflow is maintained at Active Cooling Minimum Airflow Setpoint or Active Heating Minimum Airflow Setpoint depending on the position of zone temperature with respect to Deadband midpoint and direction of temperature change.

When entering Deadband from Cooling, cooling is the controlling airflow and the heating is the blending airflow. The controlling Cooling airflow remains at Cooling Minimum Setpoint until the zone temperature falls 1 °F below the midpoint between the Heating and Cooling Temperature Setpoints. If the zone temperature falls 1 °F below the midpoint between the Heating and Cooling Temperature Setpoints, then heating air becomes the controlling airflow, and cooling becomes the blending airflow until the zone temperature rises 1 °F above the midpoint temperature.

When entering Deadband from heating, heating is the controlling airflow and cooling is the blending airflow. The controlling heating airflow remains at Heating Minimum Setpoint until the zone temperature rises 1 °F above the midpoint between the Heating and Cooling Temperature Setpoints. If the zone temperature rises 1 °F above the midpoint between the Heating and Cooling temperature setpoints, then Cooling air becomes the controlling airflow, and Heating becomes the blending airflow until the zone temperature falls 1 °F below the midpoint temperature.

If blending is used (personality 15) in the Deadband Control Mode, the blending airflow is modulated, so that the total delivered airflow does not fall below the Total Minimum Airflow Setpoint.

When cooling is the controlling airflow the Heating Airflow Setpoint is given by :

$$\text{Heating Airflow Setpoint} = \frac{\text{Blend Ratio Numerator}}{\text{Blend Ratio Denominator}} * (\text{Total Minimum Airflow Setpoint} - \text{Cooling Airflow Setpoint})$$

When heating is the controlling airflow the Cooling Airflow Setpoint is given by :

$$\text{Cooling Airflow Setpoint} = \frac{\text{Blend Ratio Numerator}}{\text{Blend Ratio Denominator}} * (\text{Total Minimum Airflow Setpoint} - \text{Heating Airflow Setpoint})$$

If blending is not used (personality 14) the blending damper is CLOSED.

## Control State

The Control State determines which Cooling and Heating Temperature Setpoints are used for zone temperature control. Four control states are possible: Occupied, Unoccupied, Night Setback, and Morning Warm-up. If the Clock is not synchronized, the Control State is Occupied by default. Otherwise the Control State is determined by the Daily Event Schedule.

The Control State may be overridden via a message broadcast over the communication bus from software or an ASIC/2-7040 controller. The controller state may be returned to OCC from NSB or Unocc when the Afterhours Enable is yes and the push-button on the Wall Sensor is pushed. The controller state may be also overridden to Unoccupied from Occupied by an the Occupancy Sensor on input 8.

The Active Cooling and Heating Minimum and Maximum Airflow Setpoints are typically given by the Occupied Cooling and Heating Minimum and Maximum Airflow Setpoints.

However, if Multiple Airflow Enable is set, the Active Cooling and Heating Minimum and Maximum Airflow Setpoints are given by: the Occupied Cooling and Heating Minimum and Maximum Airflow Setpoints in the Occupied and Morning Warm-up States; the Unoccupied Cooling and Heating Minimum and Maximum Airflow Setpoints in the Unoccupied State; or the Night Setback Cooling and Heating Minimum and Maximum Airflow Setpoints in the Night Setback State.

In the Night Setback State if NSB Option 2 is Yes, then both the Heating and Cooling Dampers are closed in deadband.

In the Unoccupied State if Unoccupied Option 2 is Yes, then both the Heating and Cooling Dampers are closed in deadband.

Morning Warm-up is meant as a prelude to Occupied state, to ready the building for daily use. For Morning Warm-up, the dual duct control sequence operates exactly as in the occupied state.

## Outputs

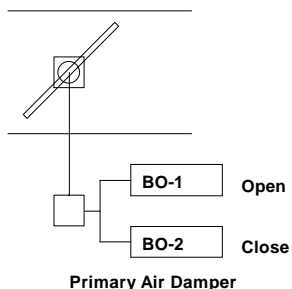

### Primary Air Damper

In Dual Duct personalities in Cooling Control mode, the controller modulates the Primary Airflow Setpoint between the Active Cooling Minimum and Maximum Airflow setpoints based on the Cooling Requirement.

The Primary Airflow is compared with the Primary Airflow Setpoint several times a second. If the difference between the primary airflow and primary airflow setpoint are greater than the Airflow Hysteresis, then the Primary Damper is drive either open or closed until the Primary Airflow is equal to the Primary Airflow Setpoint..

If blending is used (personality 15), the heating airflow is also modulated, so that the total delivered airflow does not fall below the Total Occupied Minimum Airflow setpoint.

#### **Primary Damper Control - Dual Duct Blending (Personality 15)**

\* opposite damper modulates to maintain Total Airflow SP.

January 1999

For Blending Dual Duct in deadband the midpoint between the Active Cooling and Heating Temperature Setpoints is used, with 1 degree of hysteresis to determine whether the heating duct or the cooling duct is the primary duct.

	Occupied	UNO Option 2 = No	UNO Option 2 = Yes	NSB Option 2 = No	NSB Option 2 = Yes	MWU Option 2 = Yes, or No
Cooling	Modulate	Modulate	Modulate	Modulate	Modulate	Modulate
Deadband	Modulate 50/50	Modulate 50/50	Closed	Modulate 50/50	Closed	Modulate 50/50
Heating	Modulate*	Modulate*	Modulate*	Modulate*	Modulate*	Modulate*

## Secondary Air Damper

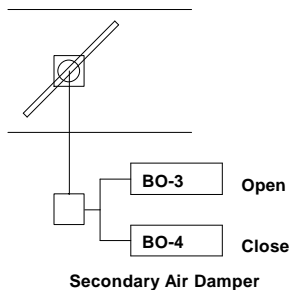

In the Heating Mode the primary airflow modulates between the Active Heating Minimum and Maximum Airflow Setpoints as the Heating requirement goes from zero to 100 %.

In dual duct personalities (personality 14,15) the Secondary Air Damper is opened or controlled to maintain a Secondary Airflow Setpoint. The Secondary Airflow is compared with the Secondary Airflow Setpoint several times a second. If the difference between the airflow and airflow setpoint are greater than the Airflow Hysteresis, then the Secondary Damper is drive either open or closed until the Secondary Airflow is equal to the Secondary Airflow Setpoint.

If blending is used (personality 15), the cooling airflow is also modulated, so that the total delivered airflow does not fall below the Total Occupied Minimum Airflow setpoint. .

### Secondary Damper Control - Dual Duct Blending (Personality 15)

\* opposite damper modulates to maintain Total Airflow SP.

	Occupied	UNO Option 2 = No	UNO Option 2 = Yes	NSB Option 2 = No	NSB Option 2 = Yes	MWU Option 2 = Yes or No
Cooling	Modulate*	Modulate*	Modulate*	Modulate*	Modulate*	Modulate*
Deadband	Modulate 50/50	Modulate 50/50	Closed	Modulate 50/50	Closed	Modulate 50/50
Heating	Modulate	Modulate	Modulate	Modulate	Modulate	Modulate

## Other Outputs

### Auxiliary Cooling Output (Optional)

An optional auxiliary cooling output is provided. If Auxiliary Cooling Enable is set, and the Cooling Requirement is 100 % and the zone temperature exceeds the active cooling setpoint by an Auxiliary Cooling Offset [Default: 2 oF] for a Auxiliary Cooling Delay Time [Default: 120 s], then an auxiliary cooling output is energized. The output to be used is assignable using the Auxiliary Cooling Output Mask [Default: Output #5]. Once energized, the auxiliary cooling output remains on until the zone temperature falls below the active cooling temperature setpoint, and the cooling airflow falls below the maximum cooling setpoint by an amount given by the Auxiliary Cooling Hysteresis. [Default: 125 ft/min]

### Auxiliary Heating Output (Optional)

If Auxiliary Heating Enable is set, the auxiliary heating output goes on whenever the controller is in the heating mode. This output is completely independent of the hot water valve or electric heat operation. It may be used to control baseboard heat used in conjunction with terminal boxes.

### Auxiliary 1, 2, 3 Output (Optional)

The ASIC/1-8055 allows up to 3 outputs for auxiliary outputs which do not follow any schedule. They can be overridden On or Off, and remain in the last state commanded. The output to be controlled is identified by the Aux 1, 2, 3 Masks which are initially un-assigned.. The functional status of the Aux 1, 2, 3 Outputs is shown by the Auxiliary 1, 2,3 Output Status .

### Lighting Output

Each ASIC/1 has the ability to control lighting. The Lighting schedule will automatically turns the lights on and off. By equipping the ASIC/1 with a WS-0XX wall sensor with push button override, the lights can be operated manually by the occupant during Occupied and Morning Warm-up States by pressing the button on the side of the zone sensor without affecting HVAC operation.

During Unoccupied and Night Setback States, depressing the push button will return the control to Occupied, and the lights will come on and stay on for Afterhours Time Allowed. During Emergency 1 and Emergency 2, the push-button has no effect.

If Lights Occupied Enable is yes then the lights are on whenever the Lighting Schedule is On, or the Control State is occupied.

Blink Warning: One minute before automatic shut off of lights as designated in the daily event schedule, or at the end of the afterhours override period, the lights will blink off and back on again. Pressing the afterhours button will re-start the lights.

## Alarms

### Zone Temperature Alarm

If the Zone temperature is above the Active Cooling Temperature Setpoint by the Zone Temperature Alarm Range, a High Zone Temperature Alarm is set. If the Zone temperature is below the Active Heating Temperature Setpoint by the Zone Temperature Alarm Range, a low Zone Temperature Alarm is set. No other actions are taken in response to a zone temperature alarm.

### Primary Airflow Alarm

If the primary airflow is above the Primary Airflow Setpoint by the Airflow Alarm Range, then a High Primary Airflow Alarm is set. If the Primary Airflow is below the Primary Airflow Setpoint by the Airflow Alarm Range, then a Low Primary Airflow Alarm is set. . No other actions are taken in response to a primary airflow alarm.

### Secondary Airflow Alarm

If the secondary airflow is above the Secondary Airflow Setpoint by the Airflow Alarm Range, then a High Secondary Airflow Alarm is set. If the Secondary Airflow is below the Secondary Airflow Setpoint by the Airflow Alarm Range, then a Low Secondary Airflow Alarm is set. . No other actions are taken in response to a secondary airflow alarm.

---

## Emergency Modes

The emergency modes, Emergency 1, and Emergency 2, are overrides which are received over the communication line and remain in effect until cleared over the communication line.

### Emergency 1 Mode

The control may only enter or exit Emergency 1 as a result of commands received on communications line. While in Emergency 1, no other state may be entered until Emergency 1 has been cleared via the communications line. Emergency is maintained through loss of power.

While in Emergency 1 state the controller immediately drives the damper to Maximum Cooling Airflow Setpoint, turns ON the lighting output, and turns OFF any other outputs.

### Emergency 2 Mode

The control can enter and exit Emergency 2 as the result of commands received on the communications line. If in Emergency 2, no other state except Emergency 1 may be entered until Emergency 2 has been cleared via the communications line. Emergency is maintained through loss of power.

While in Emergency 2 state the controller immediately drives the damper closed, turns ON the lighting output and turns OFF any other outputs.

---

## Communications

The ASIC/1-8055 communicates at 1200 baud, 9600 baud, or 19,200 baud on the remote bus using RS-485 twisted pair communication wire, connected to remote screw terminal connector, TB-4. Access to the ASI communication bus is through a SINC/2-2000 system interface which can also be used to broadcast time to synchronize the network of ASIC/1 controllers.

Communication with the remote bus can also be established through the WS-0XX wall sensor using a SINC/1-1025 Portable Interface connected to a lap-top computer running ASI SET-8055 Setup Software. It can also communicate through the WT-0XX in the remote communication mode. The local communication mode is not supported.

Each controller has a unique 16 bit address, and may also have a separate 8 bit group address. It will also respond to the global addresses 23125(5A55h) and 23130(5A5Ah).

Communication with the ASIC/1-8055 is largely compatible with the ASIC/1-8015 which it replaces. The ASIC/1-8055 may co-exist on the communication line with other ASIC/1 controllers. It is compatible with the ASI DDE Servers for seamless communication with Windows based graphic user interfaces.

## System Component Checklist

### *Inputs*

Description	Part Number	Quantity
Airflow Filter	AF-001	2
Optional Duct Temperature Sensor (IN-06)	TS-DO-8	0,1
Optional Duct Temperature Sensor (IN-07)	TS-DO-8	0,1
Optional Duct Temperature Sensor (IN-08)	TS-DO-8	0,1
Optional Occupancy Switch (BI-08)		0,1
Wall Mounted Zone Temperature Sensor	WS-0X1	1
Sensor Cable	SCP-0XX	1
Communication Cable twisted pair.	22-24 ga twisted	
ASIC/1-8055 Enclosure Cover Kit	CE-055	1

Note: The inlet side of the airflow transducer, HIGH, is marked on the ASIC/1-8055 is opposite to that of the ASIC/1-8015 controller. An airflow filter, AF-001, is required on the inlet side of the airflow transducer.

NOTE: Consult ASIC/1-8X55 Installation manual for configuration of inputs.

### *Outputs*

Description	Part Number	Quantity
VAV Controller with 2 airflow sensors	ASIC/1-8055-D	1
24 Vac Transformer		1
24 Vac Tri-state Primary Damper Operator		1
24 Vac Tri-state Secondary Damper Operator		1
24 Vac Auxiliary CLG Output Relay (Optional)		0,1
24 Vac Auxiliary HTG Output Relay(Optional)		0,1
24 Vac Auxiliary Output Relay (Optional)		0,1,2,3
24 Vac Lighting Relay (Optional)		0,1

NOTE: . The ASIC/1-8055 must be connected to a solid building ground. Metallic-oxide Varistors, MOV, may also be used across relay contacts to provide further protection from transients. If current interrupting relays are in series with the output circuits they must be protected with MOVs across the Relay Contacts

Wiring Layout

Dual Duct with or without blending

